

HIGHEST WEIGHT CATEGORIES ARISING FROM KHOVANOV'S DIAGRAM ALGEBRA II: KOSZULITY

JONATHAN BRUNDAN AND CATHARINA STROPPEL

ABSTRACT. This is the second of a series of four articles studying various generalisations of Khovanov's diagram algebra. In this article we develop the general theory of Khovanov's diagrammatically defined "projective functors" in our setting. As an application, we give a direct proof of the fact that the quasi-hereditary covers of generalised Khovanov algebras are Koszul.

CONTENTS

1. Introduction	1
2. More diagrams	3
3. Geometric bimodules	7
4. Projective functors	15
5. Kazhdan-Lusztig polynomials and Koszulity	25
6. The double centraliser property	33
7. Kostant modules	37
References	41

1. INTRODUCTION

This is Part II of a series of four articles studying some generalisations of Khovanov's diagram algebra. In Part I, we explained how to associate to every block Λ of weights two positively graded associative algebras denoted H_Λ and K_Λ . Roughly speaking, a *weight* means a diagram like

$$\lambda = \times \text{---} \circ \text{---} \wedge \text{---} \vee \text{---} \vee \text{---} \times \text{---} \wedge \text{---} \circ \text{---} \vee$$

consisting of a (possibly infinite) number line with some vertices labelled \vee , \wedge , \circ and \times . Then a *block* Λ is an equivalence class of weights, two weights being equivalent if one is obtained from the other by permuting \vee 's and \wedge 's (but not changing the positions of \circ 's and \times 's that only play an auxiliary role). If Λ consists of weights with exactly n \vee 's and n \wedge 's, then H_Λ is Khovanov's diagram algebra H_n^n from [K, §2.5] which plays a key role in the definition of Khovanov homology in knot theory. We showed in Part I that H_Λ is a symmetric algebra with a cellular basis parametrised by various closed oriented circle diagrams and that K_Λ is a quasi-hereditary algebra with a cellular basis

2000 *Mathematics Subject Classification*: 17B10, 16S37.

First author supported in part by NSF grant no. DMS-0654147.

Second author supported by the NSF and the Minerva Research Foundation DMS-0635607.

parametrised by arbitrary oriented circle diagrams. We also described explicitly the combinatorics of projective, irreducible and cell modules.

In [K, §2.7], Khovanov introduced a class of (H_m^m, H_n^n) -bimodules he called *geometric bimodules*, one for each crossingless matching between $2m$ points and $2n$ points. In this article we consider the analogous classes of bimodules for the algebras H_Λ and K_Λ in general. Tensoring with these bimodules gives rise to some remarkable functors on the module categories, which in the case of K_Λ we call *projective functors*. One of the main aims of this article is to give a systematic account of the general theory of such functors since, although elementary in nature, proofs of many of these foundational results are hard to find in the literature. We then apply the theory to give self-contained diagrammatic proofs of the following:

Koszulity. We show that the algebras K_Λ are Koszul, establishing at the same time that their Kazhdan-Lusztig polynomials in the sense of Vogan [V] are the usual Kazhdan-Lusztig polynomials associated to Grassmannians which were computed explicitly by Lascoux and Schützenberger in [LS].

Double centralizer property. We prove a double centralizer property which implies that K_Λ is a quasi-hereditary cover of H_Λ in the sense of [R, §4.2].

Kostant modules. We classify and study the Kostant modules over the algebras K_Λ in the sense of [BH]. These are the irreducible modules whose Kazhdan-Lusztig polynomials are multiplicity-free. We show that they possess a resolution by direct sums of cell modules in the spirit of [BGG].

When K_Λ is finite dimensional, these should not be regarded as new results, but the existing proofs are indirect. In fact, in the finite dimensional cases, work of Braden [Br] and the second author [S4, Theorem 5.8.1] shows that the category of K_Λ -modules is equivalent to the category of perverse sheaves on a Grassmannian (constructible with respect to the Schubert stratification). In turn, by the Beilinson-Bernstein localisation theorem from [BB], this category of perverse sheaves is equivalent to a regular integral block of a parabolic analogue of the Bernstein-Gelfand-Gelfand category \mathcal{O} associated to a maximal parabolic in type A. Using this connection to parabolic category \mathcal{O} , the fact that K_Λ is Koszul in the finite dimensional case follows as a relatively trivial special case of an important theorem of Beilinson, Ginzburg and Soergel [BGS, Theorem 1.1.3] (see also [Ba, Theorem 1.1]). Also the double centralizer property for K_Λ follows from [S1, Theorem 10.1], while our results about Kostant modules in this setting (where they correspond to the rationally smooth Schubert varieties in Grassmannians) follow from [L, BH].

The results of this article play an essential role in our subsequent work. In Part III, we apply the Koszulity and the double centralizer property to give a direct algebraic proof of the equivalence of the category of (graded) K_Λ -modules with the aforementioned blocks of (graded) parabolic category \mathcal{O} in the finite dimensional cases; this is one of the reasons we wanted to reprove the above results independently of [BB], [BGS] and [Br] in the first place. Then in Part IV, we relate some of the infinite dimensional versions of the algebra K_Λ to blocks of the general linear supergroup, a setting in which (so far) no geometric

approach is available. Since we also establish Koszulity for the (locally unital) algebras K_Λ in these infinite dimensional cases, this implies that blocks of the general linear supergroup are Koszul. Finally our treatment of Kostant modules leads to another proof of the main result of [CKL]: all irreducible polynomial representations of $GL(m|n)$ possess BGG-type resolutions.

Notation. Throughout the article we work over a fixed ground field \mathbb{F} , and gradings mean \mathbb{Z} -gradings. For a graded algebra K , we write $\text{Mod}_f(K)$ for the category of locally finite dimensional graded *left* K -modules that are bounded below; see [BS, §5] for other general conventions regarding graded modules.

2. MORE DIAGRAMS

We assume the reader is familiar with the notions of weights, blocks, cup diagrams, cap diagrams, and circle diagrams as defined in [BS, §2]. In particular, our cup and cap diagrams are allowed to contain rays as well as cups and caps, and they may also have some free vertices which are not joined to anything. In this section we generalise these diagrammatic notions by incorporating crossingless matchings.

Crossingless matchings. A *crossingless matching* means a diagram t obtained by drawing a cap diagram c underneath a cup diagram d , and then connecting rays in c to rays in d as prescribed by some order preserving bijection between the vertices of c at the bottoms of rays and the vertices of d at the tops of rays. This is possible if and only if c and d have the same number of rays; if this common number of rays is finite there is a unique such order preserving bijection. Any crossingless matching is a union of cups, caps, and *line segments* (which arise when two rays are connected). For example:

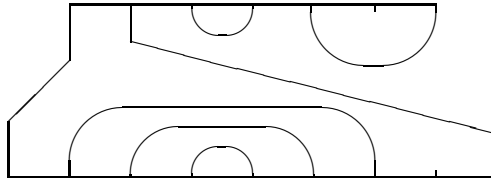

Let $\text{cups}(t)$ (resp. $\text{caps}(t)$) denote the number of cups (resp. caps) in t . Also let t^* denote the mirror image of t in a horizontal axis.

Suppose that we are given blocks Λ and Γ and a crossingless matching t . We say that t is a $\Lambda\Gamma$ -*matching* if the bottom and top number lines of t are the same as the number lines underlying weights from Λ and Γ , respectively. More generally, suppose we are given a sequence $\mathbf{\Lambda} = \Lambda_k \cdots \Lambda_0$ of blocks. A $\mathbf{\Lambda}$ -*matching* means a diagram of the form $\mathbf{t} = t_k \cdots t_1$ obtained by gluing a sequence t_1, \dots, t_k of crossingless matchings together from top (starting with t_1) to bottom (ending with t_k) such that

- ▶ t_i is a $\Lambda_i\Lambda_{i-1}$ -matching for each $i = 1, \dots, k$;
- ▶ the free vertices at the bottom of t_i are in the same positions as the free vertices at the top of t_{i+1} for each $i = 1, \dots, k - 1$.

Given in addition cup and cap diagrams a and b whose number lines are the same as the bottom and top number lines of t_k and t_1 , respectively, with free

vertices in all the same positions, we can glue to obtain a Λ -circle diagram $atb = at_k \cdots t_1 b$. Here is an example with $k = 2$:

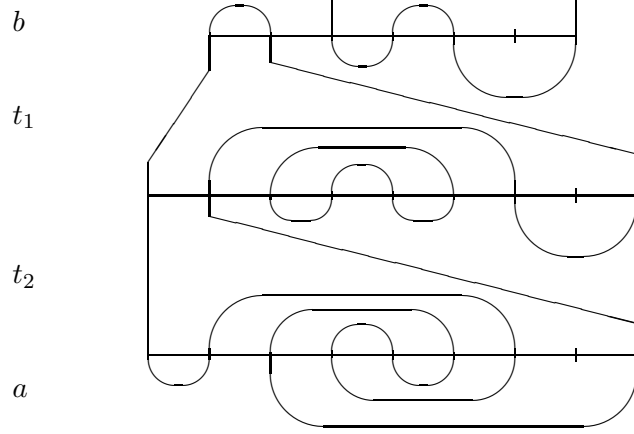

Any such circle diagram is a union of circles and lines. We call it a *closed circle diagram* if there are only circles, no lines.

Orientations and degrees. Let Λ and Γ be blocks and t be a $\Lambda\Gamma$ -matching. Given weights $\lambda \in \Lambda$ and $\mu \in \Gamma$, we can glue λ, t and μ together from bottom to top to obtain a new diagram $\lambda t \mu$. This is called an *oriented $\Lambda\Gamma$ -matching* if

- ▶ each pair of vertices lying on the same cup or the same cap is labelled so that one is \wedge and one is \vee ;
- ▶ each pair of vertices lying on the same line segment is labelled so that both are \wedge or both are \vee ;
- ▶ all other vertices are labelled either \circ or \times .

Here is an example:

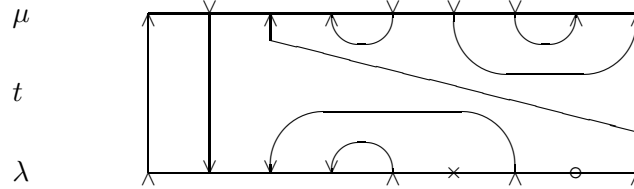

An *oriented $\Lambda\Gamma$ -circle diagram* means a composite diagram of the form $a\lambda t\mu b$ in which $\lambda t\mu$ is an oriented $\Lambda\Gamma$ -matching in the above sense and $a\lambda$ and μb are oriented cup and cap diagrams in the sense of [BS, §2].

More generally, suppose that we are given a sequence $\mathbf{\Lambda} = \Lambda_k \cdots \Lambda_0$ of blocks for some $k \geq 0$. An *oriented $\mathbf{\Lambda}$ -matching* means a composite diagram of the form

$$\mathbf{t}[\boldsymbol{\lambda}] := \lambda_k t_k \lambda_{k-1} \cdots \lambda_1 t_1 \lambda_0 \quad (2.1)$$

where $\boldsymbol{\lambda} = \lambda_k \cdots \lambda_0$ is a sequence of weights such that $\lambda_i t_i \lambda_{i-1}$ is an oriented $\Lambda_i \Lambda_{i-1}$ -matching for each $i = 1, \dots, k$. We stress that *every* number line in the diagram $\mathbf{t}[\boldsymbol{\lambda}]$ is decorated by a weight. Finally, given in addition a cup diagram a and a cap diagram b such that $a\lambda_k$ is an oriented cup diagram and $\lambda_0 b$ is an oriented cap diagram, we can glue a to the bottom and b to the top of the diagram $\mathbf{t}[\boldsymbol{\lambda}]$ to obtain an *oriented $\mathbf{\Lambda}$ -circle diagram* denoted $a\mathbf{t}[\boldsymbol{\lambda}]b$.

We say that a Λ -matching \mathbf{t} is *proper* if at least one oriented Λ -matching exists. To formulate an obvious implication of this condition, introduce the notation $\wedge(\Gamma)$ (resp. $\vee(\Gamma)$) to denote the (possibly infinite) number of vertices of a weight belonging to a block Γ that are labelled by the symbol \wedge (resp. \vee).

Lemma 2.1. *If $\mathbf{t} = t_k \cdots t_1$ is a proper Λ -matching then*

$$\begin{aligned} \wedge(\Lambda_i) - \text{caps}(t_i) &= \wedge(\Lambda_{i-1}) - \text{caps}(t_i) \geq 0, \\ \vee(\Lambda_i) - \text{caps}(t_i) &= \vee(\Lambda_{i-1}) - \text{caps}(t_i) \geq 0, \end{aligned}$$

for each $i = 1, \dots, k$.

Proof. As \mathbf{t} is proper, some oriented Λ -matching of the form (2.1) exists. Now observe that $\wedge(\Lambda_i) - \text{caps}(t_i) = \wedge(\Lambda_{i-1}) - \text{caps}(t_i)$ counts the number of line segments in the diagram $\lambda_i t_i \lambda_{i-1}$ that are oriented \wedge . This establishes the first equation, and the second is similar. \square

As in [BS, §2], we refer to a circle in an oriented Λ -circle diagram as *anti-clockwise* (type 1) or *clockwise* (type x) according to whether the leftmost vertices on the circle are labelled \vee or \wedge (equivalently, the rightmost vertices are labelled \wedge or \vee). The *degree* of a circle or a line in an oriented circle diagram means its total number of clockwise cups and caps. Finally, the degree of the oriented circle diagram itself is the sum of the degrees of its individual circles and lines.

Lemma 2.2. *The degree of an anti-clockwise circle in an oriented Λ -circle diagram is one less than the total number of caps (equivalently, cups) that it contains. The degree of a clockwise circle is one more than the total number of caps (equivalently, cups) that it contains. The degree of a line is equal to the number of caps or the number of cups that it contains, whichever is the maximum of the two.*

Proof. This is a straightforward extension of [BS, Lemma 2.1]. \square

Reductions. Suppose we are given a Λ -matching $\mathbf{t} = t_k \cdots t_1$ for some sequence $\Lambda = \Lambda_k \cdots \Lambda_0$ of blocks. We refer to the circles in the diagram \mathbf{t} that do not meet the top or bottom number lines as *internal* circles. The *reduction* of \mathbf{t} means the $\Lambda_k \Lambda_0$ -matching obtained from \mathbf{t} by removing all its internal circles and all its number lines except for the top and bottom ones. Here is an example in which one internal circle gets removed:

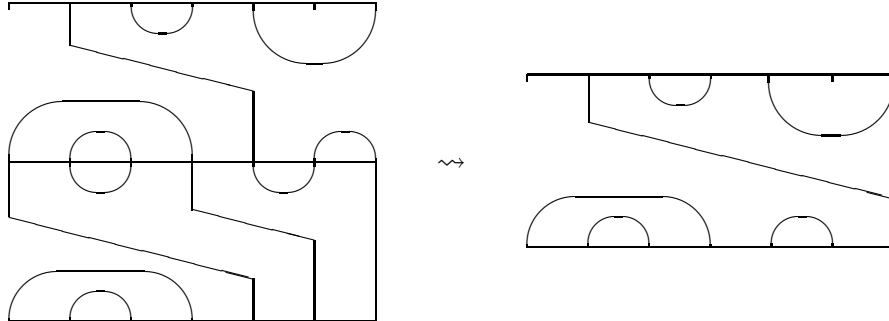

Lemma 2.3. *Assume that $a\mathbf{t}[\boldsymbol{\lambda}]b$ is an oriented Λ -circle diagram for some sequence $\boldsymbol{\lambda} = \lambda_k \cdots \lambda_0$ of weights. Let u be the reduction of \mathbf{t} . Then $a\lambda_k u \lambda_0 b$ is an oriented $\Lambda_k \Lambda_0$ -circle diagram and*

$$\begin{aligned} \deg(a\mathbf{t}[\boldsymbol{\lambda}]b) &= \deg(a\lambda_k u \lambda_0 b) + \text{caps}(t_1) + \cdots + \text{caps}(t_k) - \text{caps}(u) + p - q \\ &= \deg(a\lambda_k u \lambda_0 b) + \text{cups}(t_1) + \cdots + \text{cups}(t_k) - \text{cups}(u) + p - q, \end{aligned}$$

where p (resp. q) is the number of internal circles of \mathbf{t} that are clockwise (resp. anti-clockwise) in the diagram $a\mathbf{t}[\boldsymbol{\lambda}]b$.

Proof. Passing from $a\mathbf{t}b$ to aub involves removing all internal circles, each of which obviously has the same number of cups and caps, and also removing an equal number of cups and caps from each of the other circles and lines in the diagram. Moreover the total number of caps removed is equal to $\text{caps}(t_1) + \cdots + \text{caps}(t_k) - \text{caps}(u)$. In view of these observations, the lemma follows directly from Lemma 2.2. \square

Instead suppose that we are given a pair of blocks Λ and Γ and a $\Lambda\Gamma$ -matching t . Let a be a cup diagram whose number line agrees with the bottom number line of t . We refer to circles or lines in the composite diagram at that do not cross the top number line as *lower* circles or lines. The *lower reduction* of the diagram at means the cup diagram obtained by removing the bottom number line and all lower circles and lines. Here is an example illustrating such a lower reduction, in which one lower circle and one lower line get removed:

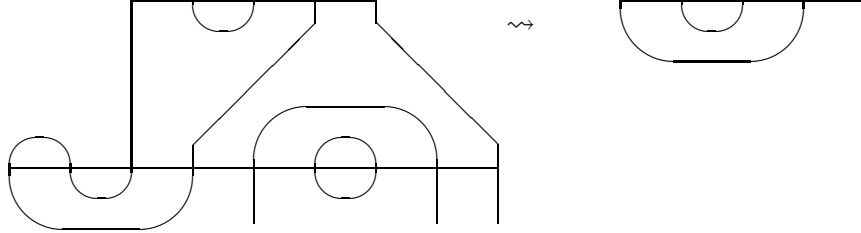

Dually, if b is a cap diagram whose number line agrees with the top number line of t , the *upper* circles and lines in the diagram tb means the ones that do not cross the bottom number line. Then the *upper reduction* of tb means the cap diagram obtained by removing the top number line and all upper circles and lines.

Lemma 2.4. *If $a\lambda t \mu b$ is an oriented $\Lambda\Gamma$ -circle diagram and c is the lower reduction of at then $c\mu b$ is an oriented circle diagram and*

$$\deg(a\lambda t \mu b) = \deg(c\mu b) + \text{caps}(t) + p - q,$$

where p (resp. q) is the number of lower circles of at that are clockwise (resp. anti-clockwise) in the diagram $a\lambda t \mu b$. For the dual statement about upper reduction, replace $\text{caps}(t)$ by $\text{cups}(t)$.

Proof. Passing from $a\mathbf{t}b$ to $c\mathbf{t}b$ involves removing lower circles, which obviously have the same number of caps and cups, and lower lines, which have one more cap than cup, and also removing an equal number of cups and caps from each

of the other circles and lines in the diagram. Moreover the total number of caps removed is equal to $\text{caps}(t)$. Now apply Lemma 2.2. \square

3. GEOMETRIC BIMODULES

In this section we generalise a construction of Khovanov [K, §2.7] associating a geometric bimodule to each crossingless matching t . Recall for any block Λ of weights that there are corresponding positively graded associative algebras H_Λ and K_Λ ; see [BS, §3] for the definition of H_Λ for Khovanov blocks, and [BS, §4] and [BS, §6] for the definitions of K_Λ and H_Λ for general blocks.

Khovanov's geometric bimodules. Assume in this subsection that $\mathbf{\Lambda} = \Lambda_k \cdots \Lambda_0$ is a sequence of Khovanov blocks, so for each $i = 0, \dots, k$ the block Λ_i consists of bounded weights with $\wedge(\Lambda_i) = \vee(\Lambda_i)$. Let $\mathbf{t} = t_k \cdots t_1$ be a $\mathbf{\Lambda}$ -matching. Using the notation (2.1), let $H_{\mathbf{\Lambda}}^{\mathbf{t}}$ be the graded vector space on homogeneous basis

$$\{(a \mathbf{t}[\boldsymbol{\lambda}] b) \mid \text{for all closed oriented } \mathbf{\Lambda}\text{-circle diagrams } a \mathbf{t}[\boldsymbol{\lambda}] b\}. \quad (3.1)$$

Note $H_{\mathbf{\Lambda}}^{\mathbf{t}}$ is non-zero if and only if \mathbf{t} is a proper $\mathbf{\Lambda}$ -matching. For example, if $k = 0$ then the sequence $\mathbf{\Lambda}$ is a single block Λ , \mathbf{t} is empty, and $H_{\mathbf{\Lambda}}^{\mathbf{t}}$ is the graded vector space underlying Khovanov's algebra H_Λ as defined in [BS, §3]. In general, define a degree preserving linear map

$$* : H_{\mathbf{\Lambda}}^{\mathbf{t}} \rightarrow H_{\mathbf{\Lambda}^*}^{\mathbf{t}^*}, \quad (a \mathbf{t}[\boldsymbol{\lambda}] b) \mapsto (b^* \mathbf{t}^*[\boldsymbol{\lambda}^*] a^*) \quad (3.2)$$

where $\mathbf{\Lambda}^* := \Lambda_0 \cdots \Lambda_k$, $\boldsymbol{\lambda}^* := \lambda_0 \cdots \lambda_k$, $\mathbf{t}^* := t_1^* \cdots t_k^*$, and a^*, b^* and t_i^* denote the mirror images of a, b and t_i in a horizontal axis.

Let $\mathbf{\Gamma} = \Gamma_l \cdots \Gamma_0$ be another sequence of Khovanov blocks such that $\Lambda_0 = \Gamma_l$. We introduce the notation $\mathbf{\Lambda} \wr \mathbf{\Gamma}$ for the concatenated sequence $\Lambda_k \cdots \Lambda_1 \Gamma_l \cdots \Gamma_0$; observe here we have skipped one copy of Λ_0 in the middle. Let $\mathbf{u} = u_l \cdots u_1$ be a $\mathbf{\Gamma}$ -matching and note that $\mathbf{t}\mathbf{u} := t_k \cdots t_1 u_l \cdots u_1$ is a $\mathbf{\Lambda} \wr \mathbf{\Gamma}$ -matching. We define a degree preserving linear multiplication

$$m : H_{\mathbf{\Lambda}}^{\mathbf{t}} \otimes H_{\mathbf{\Gamma}}^{\mathbf{u}} \rightarrow H_{\mathbf{\Lambda} \wr \mathbf{\Gamma}}^{\mathbf{t}\mathbf{u}} \quad (3.3)$$

by defining the product $(a \mathbf{t}[\boldsymbol{\lambda}] b)(c \mathbf{u}[\boldsymbol{\mu}] d)$ of two basis vectors as follows. If $b^* \neq c$ then we simply declare that $(a \mathbf{t}[\boldsymbol{\lambda}] b)(c \mathbf{u}[\boldsymbol{\mu}] d) = 0$. If $b^* = c$ then we draw the oriented circle diagram $a \mathbf{t}[\boldsymbol{\lambda}] b$ underneath $c \mathbf{u}[\boldsymbol{\mu}] d$ to create a new diagram with a symmetric middle section containing the cap diagram b underneath the cup diagram c . Then we perform surgery procedures on this middle section exactly as in [BS, §3] to obtain a disjoint union of diagrams with no cups or caps left in their middle sections. Finally, collapse the resulting diagrams by identifying the number lines above and below the middle section to obtain a disjoint union of some new closed oriented $\mathbf{\Lambda} \wr \mathbf{\Gamma}$ -circle diagrams of the form $a(\mathbf{t}\mathbf{u})[\boldsymbol{\nu}] d$, for sequences $\boldsymbol{\nu} = \nu_{k+l} \cdots \nu_0$ with

$$\nu_{k+l} \in \Lambda_k, \dots, \nu_l \in \Lambda_0, \quad \nu_l \in \Gamma_l, \dots, \nu_0 \in \Gamma_0.$$

Define the desired product $(a \mathbf{t}[\boldsymbol{\lambda}] b)(c \mathbf{u}[\boldsymbol{\mu}] d)$ to be the sum of the basis vectors of $H_{\mathbf{\Lambda} \wr \mathbf{\Gamma}}^{\mathbf{t}\mathbf{u}}$ corresponding to these diagrams.

The fact that this multiplication is well defined follows like in [BS, §3] by reinterpreting the construction in terms of a certain TQFT. Indeed, in the

special case that $k = l = 0$ the rule just described is exactly the definition of the multiplication on Khovanov's algebra given there. The multiplication m is associative in the sense that, given a third sequence Υ of Khovanov blocks such that $\Upsilon_0 = \Gamma_k$ and an Υ -matching \mathbf{s} , the following diagram commutes:

$$\begin{array}{ccc} H_{\Upsilon}^{\mathbf{s}} \otimes H_{\Lambda}^{\mathbf{t}} \otimes H_{\Gamma}^{\mathbf{u}} & \xrightarrow{1 \otimes m} & H_{\Upsilon}^{\mathbf{s}} \otimes H_{\Lambda \wr \Gamma}^{\mathbf{t}\mathbf{u}} \\ m \otimes 1 \downarrow & & \downarrow m \\ H_{\Upsilon \wr \Lambda}^{\mathbf{st}} \otimes H_{\Gamma}^{\mathbf{u}} & \xrightarrow{m} & H_{\Upsilon \wr \Lambda \wr \Gamma}^{\mathbf{stu}} \end{array} \quad (3.4)$$

Again this follows easily from the TQFT point of view. Moreover the linear map $*$ from (3.2) is anti-multiplicative in the sense that the following diagram commutes:

$$\begin{array}{ccc} H_{\Lambda}^{\mathbf{t}} \otimes H_{\Gamma}^{\mathbf{u}} & \xrightarrow{P \circ (* \otimes *)} & H_{\Gamma^*}^{\mathbf{u}^*} \otimes H_{\Lambda^*}^{\mathbf{t}^*} \\ m \downarrow & & \downarrow m \\ H_{\Lambda \wr \Gamma}^{\mathbf{tu}} & \xrightarrow{*} & H_{\Gamma^* \wr \Lambda^*}^{\mathbf{u}^* \mathbf{t}^*} \end{array} \quad (3.5)$$

where P is the flip $x \otimes y \mapsto y \otimes x$. Finally, the fact that m is a homogeneous linear map of degree zero can be checked directly using Lemma 2.2; see [BS, §3] once more for a similar argument. All the assertions just made can also be extracted from [K, §2.7].

Applying (3.4) with $H_{\Upsilon}^{\mathbf{s}} := H_{\Lambda_k}$ and $H_{\Gamma}^{\mathbf{u}} := H_{\Lambda_0}$, we see that the multiplication m defines commuting left H_{Λ_k} - and right H_{Λ_0} -actions on $H_{\Lambda}^{\mathbf{t}}$. Another couple of applications of (3.4) shows that these actions are associative. Finally, recalling the definitions of the cup and cap diagrams $\underline{\lambda}$ and $\overline{\lambda}$ associated to a weight λ from [BS, §2] and the idempotents e_{λ} from [BS, (3.3)], we have that

$$e_{\alpha}(a \mathbf{t}[\underline{\lambda}] b) = \begin{cases} (a \mathbf{t}[\underline{\lambda}] b) & \text{if } \underline{\alpha} = a, \\ 0 & \text{otherwise,} \end{cases} \quad (3.6)$$

$$(a \mathbf{t}[\underline{\lambda}] b) e_{\beta} = \begin{cases} (a \mathbf{t}[\underline{\lambda}] b) & \text{if } b = \overline{\beta}, \\ 0 & \text{otherwise,} \end{cases} \quad (3.7)$$

for $\alpha \in \Lambda_k^{\circ}, \beta \in \Lambda_0^{\circ}$ and any basis vector $(a \mathbf{t}[\underline{\lambda}] b) \in H_{\Lambda}^{\mathbf{t}}$. This implies that the H_{Λ_k} - and H_{Λ_0} -actions are unital. Hence we have made $H_{\Lambda}^{\mathbf{t}}$ into a well-defined graded $(H_{\Lambda_k}, H_{\Lambda_0})$ -bimodule. Specialising further, take $k = 1$ so that the sequence Λ is just a pair of blocks $\Lambda \Gamma$ and \mathbf{t} is a single $\Lambda \Gamma$ -matching t . In this case we usually write $H_{\Lambda \Gamma}^{\mathbf{t}}$ instead of $H_{\Lambda}^{\mathbf{t}}$, and we have shown that $H_{\Lambda \Gamma}^{\mathbf{t}}$ is a graded $(H_{\Lambda}, H_{\Gamma})$ -bimodule which is non-zero if and only if t is a proper $\Lambda \Gamma$ -matching. These bimodules are precisely Khovanov's *geometric bimodules* from [K, §2.7].

The following theorem is a generalisation of [BS, Theorem 3.1] and is essential for all subsequent constructions and proofs in this article.

Theorem 3.1. *Let notation be as in (3.3) and suppose we are given basis vectors $(a \mathbf{t}[\underline{\lambda}] b) \in H_{\Lambda}^{\mathbf{t}}$ and $(c \mathbf{u}[\underline{\mu}] d) \in H_{\Gamma}^{\mathbf{u}}$. Write $a \mathbf{t}[\underline{\lambda}] b$ as $\vec{a} \lambda b$ where $\vec{a} := a \lambda_k t_k \lambda_{k-1} \cdots \lambda_1 t_1$ and $\lambda := \lambda_0$. Similarly write $c \mathbf{u}[\underline{\mu}] d = c \vec{\mu} d$ where $\vec{\mu} := \mu_1$*

and $\vec{d} := u_l \mu_{l-1} \cdots \mu_1 u_1 \mu_0 d$. Then the multiplication satisfies

$$(\vec{a}\lambda b)(c\mu\vec{d}) = \begin{cases} 0 & \text{if } b \neq c^*, \\ s_{\vec{a}\lambda b}(\mu)(\vec{a}\mu\vec{d}) + (\dagger) & \text{if } b = c^* \text{ and } \vec{a}\mu \text{ is oriented,} \\ (\dagger) & \text{otherwise,} \end{cases}$$

where

- (i) (\dagger) denotes a linear combination of basis vectors of $H_{\Lambda|\Gamma}^{tu}$ of the form $(a(\mathbf{t}\mathbf{u})[\boldsymbol{\nu}]d)$ for $\boldsymbol{\nu} = \nu_{k+l} \cdots \nu_0$ with $\nu_l > \mu_l, \nu_{l-1} \geq \mu_{l-1}, \dots, \nu_0 \geq \mu_0$;
- (ii) the scalar $s_{\vec{a}\lambda b}(\mu) \in \{0, 1\}$ depends only on $\vec{a}\lambda b$ and μ (but not on \vec{d});
- (iii) if $b = \bar{\lambda} = c^*$ and $\vec{a}\mu$ is oriented then $s_{\vec{a}\lambda b}(\mu) = 1$;
- (iv) if $k = 0$ then the $s_{\vec{a}\lambda b}(\mu)$ is equal to the scalar $s_{a\lambda b}(\mu)$ from [BS, Theorem 3.1].

Proof. Mimic the proof of [BS, Theorem 3.1] replacing a by \vec{a} and d by \vec{d} . \square

Corollary 3.2. *The product $(a\mathbf{t}[\boldsymbol{\lambda}]b)(c\mathbf{u}[\boldsymbol{\mu}]d)$ of any pair of basis vectors of H_{Λ}^t and H_{Γ}^u is a linear combination of basis vectors of $H_{\Lambda|\Gamma}^{tu}$ of the form $(a(\mathbf{t}\mathbf{u})[\boldsymbol{\nu}]d)$ for $\boldsymbol{\nu} = \nu_{k+l} \cdots \nu_0$ with $\lambda_k \leq \nu_{k+l}, \dots, \lambda_0 \leq \nu_l \geq \mu_l, \dots, \nu_0 \geq \mu_0$.*

Proof. Theorem 3.1(i) implies that the product is a linear combination of vectors $(a(\mathbf{t}\mathbf{u})[\boldsymbol{\nu}]d)$ for $\boldsymbol{\nu} = \nu_{k+l} \cdots \nu_0$ such that $\nu_l \geq \mu_l, \dots, \nu_0 \geq \mu_0$. To show also that $\lambda_k \leq \nu_{k+l}, \dots, \lambda_0 \leq \nu_l$, use the anti-multiplicativity of the map $*$ from (3.5) and argue as in the proof of [BS, Corollary 3.2]. \square

Geometric bimodules for K_{Λ} . Now we construct the analogous geometric bimodules for the algebras K_{Λ} . Assume for this that we are given a sequence $\Lambda = \Lambda_k \cdots \Lambda_0$ of blocks for some $k \geq 0$ and a Λ -matching $\mathbf{t} = t_k \cdots t_1$, dropping the assumption that the Λ_i are Khovanov blocks. Let K_{Λ}^t be the graded vector space on homogeneous basis

$$\{(a\mathbf{t}[\boldsymbol{\lambda}]b) \mid \text{for all oriented } \Lambda\text{-circle diagrams } a\mathbf{t}[\boldsymbol{\lambda}]b\}. \quad (3.8)$$

Again, K_{Λ}^t is non-zero if and only if \mathbf{t} is proper. For example, if $k = 0$ then Λ is a single block Λ , \mathbf{t} is empty, and K_{Λ}^t is the graded vector space underlying the algebra K_{Λ} from [BS, §4]. In general, we define a degree preserving linear map

$$* : K_{\Lambda}^t \rightarrow K_{\Lambda^*}^{t^*}, \quad (a\mathbf{t}[\boldsymbol{\lambda}]b) \mapsto (b^* \mathbf{t}^*[\boldsymbol{\lambda}^*] a^*), \quad (3.9)$$

notation as in (3.2).

We want to extend the multiplication (3.3) to this new setting. In practise, this multiplication is best computed by following exactly the same steps used to compute (3.3), but replacing the surgery procedure by the generalised surgery procedure from [BS, §6]. However this approach does not easily imply that the bimodule multiplication is associative, so instead we proceed in a more round-about manner mimicing the definition of multiplication in K_{Λ} as formulated in [BS, §4]. Before we can do this, we must generalise the definitions of closure and extension from [BS, §4] to incorporate crossingless matchings.

Closures and extensions. To generalise closure, assume that Λ is a sequence of blocks of bounded weights and that $\mathbf{t} = t_k \cdots t_1$ is a proper Λ -matching. Let

$p, q \geq 0$ be integers such that $p - \wedge(\Lambda_i) = q - \vee(\Lambda_i) \geq 0$ for each i ; this is possible because the difference $\wedge(\Lambda_i) - \vee(\Lambda_i)$ is independent of i by Lemma 2.1. Using the notation [BS, (4.4)] but working always now with these new choices for p and q , let Δ_i be the block generated by $\text{cl}(\Lambda_i)$ and set $\mathbf{\Delta} := \Delta_k \cdots \Delta_0$. Also set $\text{cl}(\mathbf{t}) := \text{cl}(t_k) \cdots \text{cl}(t_1)$, where the *closure* $\text{cl}(t)$ of a crossingless matching t is obtained by adding p new vertices to the left ends and q new vertices to the right hand ends of all the number lines in t , then joining these new vertices together in order by some new vertical line segments. Finally, for an oriented $\mathbf{\Lambda}$ -circle diagram $(a \mathbf{t}[\boldsymbol{\lambda}] b)$, define its closure

$$\text{cl}(a \mathbf{t}[\boldsymbol{\lambda}] b) := \text{cl}(a) \text{cl}(\mathbf{t})[\text{cl}(\lambda_k) \cdots \text{cl}(\lambda_0)] \text{cl}(b)$$

where $\text{cl}(a)$ and $\text{cl}(b)$ are as in [BS, (4.5)–(4.6)]. In the same spirit as [BS, Lemma 4.2], this map defines a bijection between the oriented $\mathbf{\Lambda}$ -circle diagrams indexing the basis of $K_{\mathbf{\Lambda}}^{\mathbf{t}}$ and certain closed oriented $\mathbf{\Delta}$ -circle diagrams indexing part of the basis of $H_{\mathbf{\Delta}}^{\text{cl}(\mathbf{t})}$. More precisely, let $I_{\mathbf{\Lambda}}$ denote the subspace of $H_{\mathbf{\Delta}}^{\text{cl}(\mathbf{t})}$ spanned by all basis vectors $(a \text{cl}(\mathbf{t})[\boldsymbol{\lambda}] b)$ such that $\boldsymbol{\lambda} = \lambda_k \cdots \lambda_0$ with $\lambda_i \notin \text{cl}(\Lambda_i)$ for at least one $0 \leq i \leq k$. Then the map

$$\text{cl} : K_{\mathbf{\Lambda}}^{\mathbf{t}} \xrightarrow{\sim} H_{\mathbf{\Delta}}^{\text{cl}(\mathbf{t})} / I_{\mathbf{\Lambda}}, \quad (a \mathbf{t}[\boldsymbol{\lambda}] b) \mapsto (\text{cl}(a \mathbf{t}[\boldsymbol{\lambda}] b)) + I_{\mathbf{\Lambda}} \quad (3.10)$$

is a graded vector space isomorphism.

To generalise extension, given crossingless matchings s and t , we write $s \prec t$ to indicate that t can be obtained from s by extending each of its number lines then adding possibly infinitely many more vertical line segments. Now assume that we are given two sequences of arbitrary blocks, $\mathbf{\Lambda} = \Lambda_k \cdots \Lambda_0$ and $\mathbf{\Upsilon} = \Upsilon_k \cdots \Upsilon_0$, such that $\Upsilon_i \prec \Lambda_i$ for each i in the sense explained just before [BS, (4.9)]. Let $\mathbf{s} = s_k \cdots s_1$ be a proper $\mathbf{\Upsilon}$ -matching and $\mathbf{t} = t_k \cdots t_1$ be a proper $\mathbf{\Lambda}$ -matching, such that $s_i \prec t_i$ for each i . Extending the definition [BS, (4.11)] to oriented $\mathbf{\Upsilon}$ -circle diagrams, we set

$$\text{ex}_{\mathbf{\Upsilon}}^{\mathbf{\Lambda}}(a \mathbf{s}[\boldsymbol{\lambda}] b) := \text{ex}_{\Upsilon_k}^{\Lambda_k}(a) \mathbf{t}[\text{ex}_{\Upsilon_k}^{\Lambda_k}(\lambda_k) \cdots \text{ex}_{\Upsilon_0}^{\Lambda_0}(\lambda_0)] \text{ex}_{\Upsilon_0}^{\Lambda_0}(b).$$

Then the map

$$\text{ex}_{\mathbf{\Upsilon}}^{\mathbf{\Lambda}} : K_{\mathbf{\Upsilon}}^{\mathbf{s}} \hookrightarrow K_{\mathbf{\Lambda}}^{\mathbf{t}}, \quad (a \mathbf{s}[\boldsymbol{\lambda}] b) \mapsto (\text{ex}_{\mathbf{\Upsilon}}^{\mathbf{\Lambda}}(a \mathbf{s}[\boldsymbol{\lambda}] b)) \quad (3.11)$$

is a degree preserving injective linear map.

The bimodule multiplication. Finally assume $\mathbf{\Lambda} = \Lambda_k \cdots \Lambda_0$ and $\mathbf{\Gamma} = \Gamma_l \cdots \Gamma_0$ are sequences of arbitrary blocks with $\Lambda_0 = \Gamma_l$, and $\mathbf{t} = t_k \cdots t_1$ and $\mathbf{u} = u_l \cdots u_1$ are $\mathbf{\Lambda}$ - and $\mathbf{\Gamma}$ -matchings. We are ready to define a degree preserving linear multiplication

$$m : K_{\mathbf{\Lambda}}^{\mathbf{t}} \otimes K_{\mathbf{\Gamma}}^{\mathbf{u}} \rightarrow K_{\mathbf{\Lambda}\mathbf{\Gamma}}^{\mathbf{t}\mathbf{u}}. \quad (3.12)$$

If either \mathbf{t} is not a proper $\mathbf{\Lambda}$ -matching or \mathbf{u} is not a proper $\mathbf{\Gamma}$ -matching then $K_{\mathbf{\Lambda}}^{\mathbf{t}} \otimes K_{\mathbf{\Gamma}}^{\mathbf{u}} = \{0\}$, and we simply have to take $m := 0$. Assume from now on that both \mathbf{t} and \mathbf{u} are both proper.

Suppose to start with that each Λ_i and each Γ_j consists of bounded weights. Applying Lemma 2.1, we can pick $p, q \geq 0$ so that $p - \wedge(\Lambda_i) = q - \vee(\Lambda_i) \geq 0$ and $p - \wedge(\Gamma_j) = q - \vee(\Gamma_j) \geq 0$ for all i, j ; it is easy to see that the construction we are about to explain is independent of the particular choices of p, q just

made. Let $\Delta := \Delta_k \cdots \Delta_0$ where Δ_i is the block generated by $\text{cl}(\Lambda_i)$ and $\Pi := \Pi_l \cdots \Pi_0$ where Π_i is the block generated by $\text{cl}(\Gamma_i)$. Noting also that $\text{cl}(\mathbf{t})\text{cl}(\mathbf{u}) = \text{cl}(\mathbf{tu})$, the isomorphism (3.10) gives the following three graded vector space isomorphisms:

$$\text{cl} : K_{\Lambda}^{\mathbf{t}} \xrightarrow{\sim} H_{\Delta}^{\text{cl}(\mathbf{t})}/I_{\Lambda}, \quad K_{\Gamma}^{\mathbf{u}} \xrightarrow{\sim} H_{\Pi}^{\text{cl}(\mathbf{u})}/I_{\Gamma}, \quad K_{\Lambda\Gamma}^{\mathbf{tu}} \xrightarrow{\sim} H_{\Delta\Pi}^{\text{cl}(\mathbf{tu})}/I_{\Lambda\Gamma}. \quad (3.13)$$

By [BS, Lemma 4.1] and Corollary 3.2, the multiplication map

$$H_{\Delta}^{\text{cl}(\mathbf{t})} \otimes H_{\Pi}^{\text{cl}(\mathbf{u})} \rightarrow H_{\Delta\Pi}^{\text{cl}(\mathbf{tu})}$$

from (3.3) has the properties that $I_{\Lambda}H_{\Pi}^{\text{cl}(\mathbf{u})} \subseteq I_{\Lambda\Gamma}$ and $H_{\Delta}^{\text{cl}(\mathbf{t})}I_{\Gamma} \subseteq I_{\Lambda\Gamma}$. Hence it factors through the quotients to give a well-defined degree preserving linear map

$$\left(H_{\Delta}^{\text{cl}(\mathbf{t})}/I_{\Lambda} \right) \otimes \left(H_{\Pi}^{\text{cl}(\mathbf{u})}/I_{\Gamma} \right) \rightarrow H_{\Delta\Pi}^{\text{cl}(\mathbf{tu})}/I_{\Lambda\Gamma}.$$

Transporting this through the isomorphisms cl from (3.13), we obtain the desired multiplication (3.12).

It remains to drop the assumption that each Λ_i and Γ_j consists of bounded weights; formally this involves taking direct limits as explained immediately after [BS, Lemma 4.3] but we will suppress the details. Take vectors $x \in K_{\Lambda}^{\mathbf{t}}$ and $y \in K_{\Gamma}^{\mathbf{u}}$. Recalling (3.11), choose sequences of blocks $\Upsilon = \Upsilon_k \cdots \Upsilon_0$ and $\Omega = \Omega_l \cdots \Omega_0$ and proper Υ - and Ω -matchings $\mathbf{r} = r_k \cdots r_1$ and $\mathbf{s} = s_l \cdots s_1$ such that

- ▶ $\Upsilon_i \prec \Lambda_i$ and $r_i \prec t_i$ for each i , and $\Omega_j \prec \Gamma_j$ and $s_j \prec u_j$ for each j ;
- ▶ x is in the image of the map $\text{ex}_{\Upsilon}^{\Lambda} : K_{\Upsilon}^{\mathbf{r}} \hookrightarrow K_{\Lambda}^{\mathbf{t}}$, and y is in the image of the map $\text{ex}_{\Omega}^{\Gamma} : K_{\Omega}^{\mathbf{s}} \hookrightarrow K_{\Gamma}^{\mathbf{u}}$.

Then we truncate by applying the inverse maps to $\text{ex}_{\Upsilon}^{\Lambda}$ and $\text{ex}_{\Omega}^{\Gamma}$ to x and y , respectively, compute the resulting bounded product as in the previous paragraph to obtain an element of $K_{\Upsilon\Omega}^{\mathbf{rs}}$, then finally apply the map $\text{ex}_{\Upsilon\Omega}^{\Lambda\Gamma}$ to get the desired product $xy \in K_{\Lambda\Gamma}^{\mathbf{tu}}$. This completes the definition of the multiplication (3.12) in general.

Using the associativity from (3.4), one checks that the new multiplication is also associative in the same sense. Also, the map $*$ from (3.9) is anti-multiplicative in the same sense as (3.5). Finally (3.6)–(3.7) remain true in the new setting for arbitrary $\alpha \in \Lambda_k, \beta \in \Lambda_0$ and any $(a \mathbf{t}[\boldsymbol{\lambda}] b) \in K_{\Lambda}^{\mathbf{t}}$. So as before m makes $K_{\Lambda}^{\mathbf{t}}$ into a well-defined graded $(K_{\Lambda_k}, K_{\Lambda_0})$ -bimodule. Generalising the decomposition [BS, (4.13)], we also have that

$$K_{\Lambda}^{\mathbf{t}} = \bigoplus_{\alpha \in \Lambda_r, \beta \in \Lambda_0} e_{\alpha} K_{\Lambda}^{\mathbf{t}} e_{\beta}. \quad (3.14)$$

By considering the explicit parametrisation of the basis using (a slightly modified version of) [BS, Lemma 2.4(i)], it follows that each summand on the right hand side of (3.14) is finite dimensional. Moreover $K_{\Lambda}^{\mathbf{t}}$ itself is locally finite dimensional and bounded below.

The following theorem is a generalisation of [BS, Theorem 4.4]. We stress that its statement is *exactly the same* as the statement of Theorem 3.1, just with H replaced by K everywhere.

Theorem 3.3. *Let notation be as in (3.12) and suppose we are given basis vectors $(a \mathbf{t}[\boldsymbol{\lambda}] b) \in K_{\Lambda}^{\mathbf{t}}$ and $(c \mathbf{u}[\boldsymbol{\mu}] d) \in K_{\Gamma}^{\mathbf{u}}$. Write $a \mathbf{t}[\boldsymbol{\lambda}] b$ as $\vec{a} \lambda b$ where $\vec{a} := a \lambda_k t_k \lambda_{k-1} \cdots \lambda_1 t_1$ and $\lambda := \lambda_0$. Similarly write $c \mathbf{u}[\boldsymbol{\mu}] d = c \boldsymbol{\mu} \vec{d}$ where $\boldsymbol{\mu} := \mu_l$ and $\vec{d} := u_l \mu_{l-1} \cdots \mu_1 u_1 \mu_0 d$. Then the multiplication satisfies*

$$(\vec{a} \lambda b)(c \boldsymbol{\mu} \vec{d}) = \begin{cases} 0 & \text{if } b \neq c^*, \\ s_{\vec{a} \lambda b}(\boldsymbol{\mu})(\vec{a} \boldsymbol{\mu} \vec{d}) + (\dagger) & \text{if } b = c^* \text{ and } \vec{a} \boldsymbol{\mu} \text{ is oriented,} \\ (\dagger) & \text{otherwise,} \end{cases}$$

where

- (i) (\dagger) denotes a linear combination of basis vectors of $K_{\Lambda \wr \Gamma}^{\mathbf{t} \mathbf{u}}$ of the form $(a(\mathbf{t} \mathbf{u})[\boldsymbol{\nu}] d)$ for $\boldsymbol{\nu} = \nu_{k+l} \cdots \nu_0$ with $\nu_l > \mu_l, \nu_{l-1} \geq \mu_{l-1}, \dots, \nu_0 \geq \mu_0$;
- (ii) the scalar $s_{\vec{a} \lambda b}(\boldsymbol{\mu}) \in \{0, 1\}$ depends only on $\vec{a} \lambda b$ and $\boldsymbol{\mu}$ (but not on \vec{d});
- (iii) if $b = \bar{\lambda} = c^*$ and $\vec{a} \boldsymbol{\mu}$ is oriented then $s_{\vec{a} \lambda b}(\boldsymbol{\mu}) = 1$;
- (iv) if $k = 0$ then the $s_{\vec{a} \lambda b}(\boldsymbol{\mu})$ is equal to the scalar $s_{a \lambda b}(\boldsymbol{\mu})$ from [BS, Theorem 4.4].

Proof. This follows from Theorem 3.1 above in the same fashion as [BS, Theorem 4.4] follows from [BS, Theorem 3.1]. \square

Corollary 3.4. *The product $(a \mathbf{t}[\boldsymbol{\lambda}] b)(c \mathbf{u}[\boldsymbol{\mu}] d)$ of any pair of basis vectors of $K_{\Lambda}^{\mathbf{t}}$ and $K_{\Gamma}^{\mathbf{u}}$ is a linear combination of basis vectors of $K_{\Lambda \wr \Gamma}^{\mathbf{t} \mathbf{u}}$ of the form $(a(\mathbf{t} \mathbf{u})[\boldsymbol{\nu}] d)$ for $\boldsymbol{\nu} = \nu_{k+l} \cdots \nu_0$ with $\lambda_k \leq \nu_{k+l}, \dots, \lambda_0 \leq \nu_l \geq \mu_l, \dots, \nu_0 \geq \mu_0$.*

Proof. Argue as in the proof of Corollary 3.2 using the analogue of (3.5). \square

Composition of geometric bimodules. The next theorem is crucial and is an extension of [K, Theorem 1].

Theorem 3.5. *Let notation be as in (3.12), so the tensor product $K_{\Lambda}^{\mathbf{t}} \otimes_{K_{\Lambda_0}} K_{\Gamma}^{\mathbf{u}}$ is a well-defined graded $(K_{\Lambda_k}, K_{\Gamma_0})$ -bimodule.*

- (i) *Any vector $(a \mathbf{t}[\boldsymbol{\lambda}] b) \otimes (c \mathbf{u}[\boldsymbol{\mu}] d) \in K_{\Lambda}^{\mathbf{t}} \otimes_{K_{\Lambda_0}} K_{\Gamma}^{\mathbf{u}}$ is a linear combination of vectors of the form*

$$(a \mathbf{t}[\nu_{k+l} \cdots \nu_l] \bar{\nu}_l) \otimes (\underline{\nu}_l \mathbf{u}[\nu_l \cdots \nu_0] d) \quad (3.15)$$

for $\boldsymbol{\nu} = \nu_{k+l} \cdots \nu_0$ such that $a(\mathbf{t} \mathbf{u})[\boldsymbol{\nu}] d$ is an oriented $\Lambda \wr \Gamma$ -circle diagram and $\lambda_k \leq \nu_{k+l}, \dots, \lambda_0 \leq \nu_l \geq \mu_l, \dots, \nu_0 \geq \mu_0$.

- (ii) *The vectors (3.15) for all oriented $\Lambda \wr \Gamma$ -circle diagrams $a(\mathbf{t} \mathbf{u})[\boldsymbol{\nu}] d$ form a basis for $K_{\Lambda}^{\mathbf{t}} \otimes_{K_{\Lambda_0}} K_{\Gamma}^{\mathbf{u}}$.*
- (iii) *The multiplication m from (3.12) induces an isomorphism*

$$\bar{m} : K_{\Lambda}^{\mathbf{t}} \otimes_{K_{\Lambda_0}} K_{\Gamma}^{\mathbf{u}} \xrightarrow{\sim} K_{\Lambda \wr \Gamma}^{\mathbf{t} \mathbf{u}}.$$

of graded $(K_{\Lambda_k}, K_{\Gamma_0})$ -bimodules.

Proof. (i) Assume for a contradiction that (i) is false. Fix cup and cap diagrams a and d such that the statement of (i) is wrong for some $\boldsymbol{\lambda}, \boldsymbol{\mu}, b$ and c . Let

$$S := \left\{ (\boldsymbol{\lambda}, \boldsymbol{\mu}) \left| \begin{array}{l} \boldsymbol{\lambda} = \lambda_k \cdots \lambda_0 \text{ with each } \lambda_i \in \Lambda_i, \\ \boldsymbol{\mu} = \mu_l \cdots \mu_0 \text{ with each } \mu_j \in \Gamma_j, \\ a \mathbf{t}[\boldsymbol{\lambda}] \text{ and } \mathbf{u}[\boldsymbol{\mu}] d \text{ are oriented} \end{array} \right. \right\}$$

Put a partial order on S by declaring that $(\boldsymbol{\lambda}, \boldsymbol{\mu}) \leq (\boldsymbol{\lambda}', \boldsymbol{\mu}')$ if $\lambda_i \leq \lambda'_i$ and $\mu_j \leq \mu'_j$ for all i and j . For $(\boldsymbol{\lambda}, \boldsymbol{\mu}) \in S$, let $K(\boldsymbol{\lambda}, \boldsymbol{\mu})$ denote the span of all the vectors of the form (3.15) for $\boldsymbol{\nu} = \nu_{k+l} \cdots \nu_0$ such that $a(\mathbf{t}\mathbf{u})[\boldsymbol{\nu}]d$ is an oriented $\mathbf{\Lambda} \wr \mathbf{\Gamma}$ -circle diagram and $\lambda_k \leq \nu_{k+l}, \dots, \lambda_0 \leq \nu_l \geq \mu_l, \dots, \nu_0 \geq \mu_0$. Because the set S is necessarily finite (see [BS, Lemma 2.4(i)]), we can choose $(\boldsymbol{\lambda}, \boldsymbol{\mu}) \in S$ maximal such that

$$(a\mathbf{t}[\boldsymbol{\lambda}]b) \otimes (c\mathbf{u}[\boldsymbol{\mu}]d) \notin K(\boldsymbol{\lambda}, \boldsymbol{\mu})$$

for some b and c . To get a contradiction from this, we now split into two cases according to whether $\lambda_0 \not\leq \mu_l$ or $\lambda_0 \not\geq \mu_l$.

Suppose to start with that $\lambda_0 \not\leq \mu_l$. By Theorem 3.3(iii) and Corollary 3.4, we have that

$$(a\mathbf{t}[\boldsymbol{\lambda}]\bar{\lambda}_0)(\Delta_0\lambda_0b) = (a\mathbf{t}[\boldsymbol{\lambda}]b) + (\dagger)$$

where (\dagger) is a linear combination of $(a\mathbf{t}[\boldsymbol{\lambda}']b)$'s with $(\boldsymbol{\lambda}, \boldsymbol{\mu}) < (\boldsymbol{\lambda}', \boldsymbol{\mu}')$. By maximality of $(\boldsymbol{\lambda}, \boldsymbol{\mu})$, we deduce that $(\dagger) \otimes (c\mathbf{u}[\boldsymbol{\mu}]d)$ is contained in $K(\boldsymbol{\lambda}', \boldsymbol{\mu}')$, hence in $K(\boldsymbol{\lambda}, \boldsymbol{\mu})$ too. Hence

$$(a\mathbf{t}[\boldsymbol{\lambda}]\bar{\lambda}_0)(\Delta_0\lambda_0b) \otimes (c\mathbf{u}[\boldsymbol{\mu}]d) = (a\mathbf{t}[\boldsymbol{\lambda}]\bar{\lambda}_0) \otimes (\Delta_0\lambda_0b)(c\mathbf{u}[\boldsymbol{\mu}]d) \notin K(\boldsymbol{\lambda}, \boldsymbol{\mu}).$$

By Theorem 3.3(i)–(ii), we can expand

$$(\Delta_0\lambda_0b)(c\mathbf{u}[\boldsymbol{\mu}]d) = (\Delta_0\mathbf{u}[\boldsymbol{\mu}]d) + (\ddagger)$$

where the first term on the right hand side should be omitted unless $b = c^*$, $\Delta_0\mu_l$ is oriented and $s_{\Delta_0\lambda_0b}(\mu_l) = 1$, and (\ddagger) denotes a linear combination of $(\Delta_0\mathbf{u}[\boldsymbol{\mu}']d)$'s with $(\boldsymbol{\lambda}, \boldsymbol{\mu}) < (\boldsymbol{\lambda}', \boldsymbol{\mu}')$. By maximality again, $(a\mathbf{t}[\boldsymbol{\lambda}]\bar{\lambda}_0) \otimes (\ddagger)$ is contained in $K(\boldsymbol{\lambda}, \boldsymbol{\mu})$. Hence the first term on the right hand side must be present and we have proved that

$$(\ddagger) := (a\mathbf{t}[\boldsymbol{\lambda}]\bar{\lambda}_0) \otimes (\Delta_0\mathbf{u}[\boldsymbol{\mu}]d) \notin K(\boldsymbol{\lambda}, \boldsymbol{\mu}).$$

This shows in particular that $\Delta_0\mu_l$ is oriented, hence $\lambda_0 \leq \mu_l$ by [BS, Lemma 2.3]. Because $\lambda_0 \not\leq \mu_l$ we deduce that $\lambda_0 = \mu_l$. Hence (\ddagger) is equal to the vector (3.15) for $\boldsymbol{\nu} := \lambda_k \cdots \lambda_1 \mu_l \cdots \mu_0$. So we also have $(\ddagger) \in K(\boldsymbol{\lambda}, \boldsymbol{\mu})$, contradiction.

Assume instead that $\lambda_0 \not\geq \mu_l$. Then we can apply the anti-multiplicative map $*$ from (3.9) to reduce to exactly the situation of the previous paragraph, hence get a similar contradiction.

(ii), (iii) By the associativity of multiplication, the images of $xh \otimes y$ and $x \otimes hy$ are equal for $x \in K_{\mathbf{\Lambda}}^t$, $h \in K_{\Lambda_0}$ and $y \in K_{\mathbf{\Gamma}}^u$. Hence the multiplication map m factors through the quotient to induce a well-defined graded bimodule homomorphism \bar{m} as in (iii). To prove that it is an isomorphism, it suffices to show that the restriction

$$\bar{m} : e_{\alpha}K_{\mathbf{\Lambda}}^t \otimes_{K_{\Lambda_0}} K_{\mathbf{\Gamma}}^u e_{\beta} \rightarrow e_{\alpha}K_{\mathbf{\Lambda} \wr \mathbf{\Gamma}}^{\mathbf{t}\mathbf{u}} e_{\beta}$$

is a vector space isomorphism for each fixed $\alpha \in \Lambda_k$ and $\beta \in \Gamma_0$. Note the vector space on the right hand side is finite dimensional, with basis given by the vectors $y(\boldsymbol{\nu}) := (\underline{\alpha}(\mathbf{t}\mathbf{u})[\boldsymbol{\nu}]\bar{\beta})$ for all $\boldsymbol{\nu}$ such that $\underline{\alpha}(\mathbf{t}\mathbf{u})[\boldsymbol{\nu}]\bar{\beta}$ is an oriented $\mathbf{\Lambda} \wr \mathbf{\Gamma}$ -circle diagram. In view of (i), we know already that the vectors $x(\boldsymbol{\nu}) := (\underline{\alpha}\mathbf{t}[\nu_{k+l} \cdots \nu_l]\bar{\nu}_l) \otimes (\underline{\nu}_l\mathbf{u}[\nu_l \cdots \nu_0]\bar{\beta})$ indexed by the same set of $\boldsymbol{\nu}$'s span $e_{\alpha}K_{\mathbf{\Lambda}}^t \otimes_{K_{\Lambda_0}} K_{\mathbf{\Gamma}}^u e_{\beta}$. Moreover, $\bar{m}(x(\boldsymbol{\nu}))$ is equal to $y(\boldsymbol{\nu})$ plus higher terms by Theorem 3.3(iii) and Corollary 3.4, so \bar{m} is surjective. Combining these two

statements we deduce that \overline{m} is actually an isomorphism giving (iii), and at the same time we see that the $x(\nu)$'s form a basis giving (ii). \square

Reduction of geometric bimodules. The following theorem reduces the study of the bimodules K_{Λ}^t for arbitrary sequences $\Lambda = \Lambda_k \cdots \Lambda_0$ and $t = t_k \cdots t_1$ just to the bimodules of the form $K_{\Lambda\Gamma}^t$ for fixed blocks Λ and Γ and a single $\Lambda\Gamma$ -matching t , greatly simplifying all our notation in the remainder of the article. Let R denote the algebra $\mathbb{F}[x]/(x^2)$. This is a Frobenius algebra with counit

$$\tau : R \rightarrow \mathbb{F}, \quad 1 \mapsto 0, \quad x \mapsto 1. \quad (3.16)$$

We view R as a graded vector space so that 1 is in degree -1 and x is in degree one. The multiplication and comultiplication are then homogeneous of degree one.

Theorem 3.6. *Suppose that $\Lambda = \Lambda_k \cdots \Lambda_0$ is a sequence of blocks and $t = t_k \cdots t_1$ is a proper Λ -matching. Let u be the reduction of t and let n be the number of internal circles removed in the reduction process. Then we have that*

$$\begin{aligned} K_{\Lambda}^t &\cong K_{\Lambda_k \Lambda_0}^u \otimes R^{\otimes n} \langle \text{caps}(t_1) + \cdots + \text{caps}(t_k) - \text{caps}(u) \rangle \\ &= K_{\Lambda_k \Lambda_0}^u \otimes R^{\otimes n} \langle \text{cups}(t_1) + \cdots + \text{cups}(t_k) - \text{cups}(u) \rangle \end{aligned}$$

as graded $(K_{\Lambda_k}, K_{\Lambda_0})$ -bimodules (viewing $K_{\Lambda_k \Lambda_0}^u \otimes R^{\otimes n}$ as a bimodule via the natural action on the first tensor factor).

Proof. Enumerating the n internal circles in the diagram t in some fixed order, we define a linear map

$$f : K_{\Lambda}^t \rightarrow K_{\Lambda_k \Lambda_0}^u \otimes R^{\otimes n}, \quad (a t[\lambda] b) \mapsto (a \lambda_k u \lambda_0 b) \otimes x_1 \otimes \cdots \otimes x_n$$

where each x_i is 1 or x according to whether the i th internal circle of t is anti-clockwise or clockwise in the diagram $a t[\lambda] b$. This map is obviously a bijection. Moreover, because the internal circles play no role in the bimodule structure, it is a $(K_{\Lambda_k}, K_{\Lambda_0})$ -bimodule homomorphism. Finally Lemma 2.3 implies that f is a homogeneous linear map of degree $-\text{caps}(t_1) - \cdots - \text{caps}(t_r) + \text{caps}(u) = -\text{cups}(t_1) - \cdots - \text{cups}(t_r) + \text{cups}(u)$. This accounts for the degree shift in the statement of the theorem. \square

Geometric bimodules for H_{Λ} . For an arbitrary block Λ , recall that the generalised Khovanov algebra is the subalgebra

$$H_{\Lambda} := \bigoplus_{\alpha, \beta \in \Lambda^{\circ}} e_{\alpha} K_{\Lambda} e_{\beta} \quad (3.17)$$

of K_{Λ} , where Λ° is the subset of Λ consisting of all weights of maximal defect. Given another block Γ and a $\Lambda\Gamma$ -matching t , we define

$$H_{\Lambda\Gamma}^t := \bigoplus_{\alpha \in \Lambda^{\circ}, \beta \in \Gamma^{\circ}} e_{\alpha} K_{\Lambda\Gamma}^t e_{\beta}. \quad (3.18)$$

This is naturally a graded $(H_{\Lambda}, H_{\Gamma})$ -bimodule, and if Λ and Γ are Khovanov blocks it is the same as Khovanov's geometric bimodule $H_{\Lambda\Gamma}^t$ defined earlier. We refer to the $H_{\Lambda\Gamma}^t$'s as *geometric bimodules* for arbitrary blocks Λ and Γ too.

We are not going to say anything else about these geometric bimodules in the rest of the article, since we are mainly interested in the $K_{\Lambda\Gamma}^t$'s. However using the truncation functor

$$e : \text{Mod}_f(K_\Lambda) \rightarrow \text{Mod}_f(H_\Lambda), \quad M \mapsto \bigoplus_{\lambda \in \Lambda^\circ} e_\lambda M \quad (3.19)$$

from [BS, (6.13)] it is usually a routine exercise to deduce analogues for the $H_{\Lambda\Gamma}^t$'s of all our subsequent results about the $K_{\Lambda\Gamma}^t$'s. In doing this, it is useful to note that there is an isomorphism

$$e_\Lambda \circ K_{\Lambda\Gamma}^t \otimes_{K_\Gamma} ? \cong H_{\Lambda\Gamma}^t \otimes_{H_\Gamma} ? \circ e_\Gamma \quad (3.20)$$

of functors from $\text{Mod}_f(K_\Gamma)$ to $\text{Mod}_f(H_\Lambda)$, where we have added the subscripts Λ and Γ to the e 's to avoid confusion. Since we do not need any of these results here, we omit the details. The main point to prove (3.20) is to observe that all indecomposable summands of $e_\Lambda K_{\Lambda\Gamma}^t$ as a right K_Γ -module are also summands of $e_\Gamma K_\Gamma$ (up to degree shifts), which is a consequence of Theorem 4.2 below.

4. PROJECTIVE FUNCTORS

Fix blocks Λ and Γ throughout the section. We are going to study projective functors that arise by tensoring with geometric bimodules.

Projective functors are exact. Given a proper $\Lambda\Gamma$ -matching t , tensoring with the geometric bimodule $K_{\Lambda\Gamma}^t$ defines a functor

$$G_{\Lambda\Gamma}^t := K_{\Lambda\Gamma}^t \langle - \text{caps}(t) \rangle \otimes_{K_\Gamma} ? : \text{Mod}_f(K_\Gamma) \rightarrow \text{Mod}_f(K_\Lambda) \quad (4.1)$$

between the graded module categories. The extra degree shift by $-\text{caps}(t)$ in this definition is included to ensure that $G_{\Lambda\Gamma}^t$ commutes with duality; see Theorem 4.10 below. We will call any functor that is isomorphic to a finite direct sum of such functors (possibly shifted in degree) a *projective functor*. Note Theorems 3.5(iii) and 3.6 imply that the composition of two projective functors is again a projective functor. Moreover, in view of the next lemma, projective functors corresponding to ‘‘identity matchings’’ are equivalences of categories.

Lemma 4.1. *If t is a proper $\Lambda\Gamma$ -matching containing no cups or caps then the functor $G_{\Lambda\Gamma}^t : \text{Mod}_f(K_\Gamma) \rightarrow \text{Mod}_f(K_\Lambda)$ is an equivalence of categories.*

Proof. The matching t determines an order-preserving bijection $f : \Lambda \rightarrow \Gamma$, $\lambda \mapsto \gamma$ such that $\underline{\gamma}$ is the lower reduction of $\underline{\lambda}t$. Moreover the induced map

$$f : K_\Lambda \rightarrow K_\Gamma, \quad (\underline{\alpha\lambda\beta}) \mapsto (\underline{f(\alpha)f(\lambda)f(\beta)})$$

is an isomorphism of graded algebras. Identifying K_Λ with K_Γ in this way, the (K_Λ, K_Γ) -bimodule $K_{\Lambda\Gamma}^t$ is isomorphic to the regular (K_Γ, K_Γ) -bimodule K_Γ . Since $G_{\Lambda\Gamma}^t$ is the functor defined by tensoring with this bimodule, the lemma follows. \square

The next important theorem describes explicitly the effect of a projective functor on the projective indecomposable modules $P(\lambda) := K_\Lambda e_\lambda$ from [BS, §5]. Recall the graded vector space R defined immediately before (3.16).

Theorem 4.2. *Let t be a proper $\Lambda\Gamma$ -matching and $\gamma \in \Gamma$.*

- (i) *We have that $G_{\Lambda\Gamma}^t P(\gamma) \cong K_{\Lambda\Gamma}^t e_\gamma \langle -\text{caps}(t) \rangle$ as left K_Λ -modules.*
- (ii) *The module $G_{\Lambda\Gamma}^t P(\gamma)$ is non-zero if and only if the rays of each upper line in $t\gamma\bar{\gamma}$ are oriented so that one is \wedge and one is \vee .*
- (iii) *Assuming the condition from (ii) is satisfied, define $\lambda \in \Lambda$ by declaring that $\bar{\lambda}$ is the upper reduction of $t\bar{\gamma}$, and let n be the number of upper circles removed in the reduction process. Then*

$$G_{\Lambda\Gamma}^t P(\gamma) \cong P(\lambda) \otimes R^{\otimes n} \langle \text{cups}(t) - \text{caps}(t) \rangle.$$

as graded left K_Λ -modules (where the K_Λ -action on $P(\lambda) \otimes R^{\otimes n}$ comes from its action on the first tensor factor).

Proof. Note to start with that

$$\begin{aligned} G_{\Lambda\Gamma}^t P(\gamma) &= K_{\Lambda\Gamma}^t \langle -\text{caps}(t) \rangle \otimes_{K_\Gamma} P(\gamma) \\ &= K_{\Lambda\Gamma}^t \otimes_{K_\Gamma} K_\Gamma e_\gamma \langle -\text{caps}(t) \rangle \cong K_{\Lambda\Gamma}^t e_\gamma \langle -\text{caps}(t) \rangle, \end{aligned}$$

as asserted in (i).

We next establish the forward implication of (ii). Suppose that the rays of some upper line in the diagram $t\gamma\bar{\gamma}$ are oriented so that both are \wedge or both are \vee . For any $\nu \in \Gamma$ such that $\nu\bar{\gamma}$ is oriented, the rays in $\nu\bar{\gamma}$ are oriented in the same way as in $\gamma\bar{\gamma}$. It follows that there are no weights $\mu \in \Lambda, \nu \in \Gamma$ such that both $\nu\bar{\gamma}$ and $\mu\nu$ are oriented. Since $K_{\Lambda\Gamma}^t e_\gamma$ has a basis indexed by oriented circle diagrams of the form $a\mu\nu\bar{\gamma}$, this implies that $K_{\Lambda\Gamma}^t e_\gamma = \{0\}$. Hence also $G_{\Lambda\Gamma}^t P(\gamma) = \{0\}$ by (i), as required.

Now to complete the proof we assume that the rays of every upper line in $t\gamma\bar{\gamma}$ are oriented so one is \wedge and one is \vee . Enumerate the n upper circles in the diagram $t\bar{\gamma}$ in some fixed order. Then the map

$$f : K_{\Lambda\Gamma}^t e_\gamma \rightarrow K_\Lambda e_\lambda \otimes R^{\otimes n}, \quad (a\mu\nu\bar{\gamma}) \mapsto (a\mu\bar{\lambda}) \otimes x_1 \otimes \cdots \otimes x_n,$$

where x_i is 1 or x according to whether the i th upper circle of $t\bar{\gamma}$ is anti-clockwise or clockwise in $a\mu\nu\bar{\gamma}$, is an isomorphism of left K_Λ -modules. Moreover f is homogeneous of degree $\text{cups}(t)$ by Lemma 2.4. Since $P(\lambda) = K_\Lambda e_\lambda$ and $G_{\Lambda\Gamma}^t P(\gamma) \cong K_{\Lambda\Gamma}^t e_\gamma \langle -\text{caps}(t) \rangle$, this proves (iii). It also shows that $G_{\Lambda\Gamma}^t P(\gamma)$ is non-zero, completing the proof of (ii) as well. \square

Corollary 4.3. *$K_{\Lambda\Gamma}^t$ is projective both as a left K_Λ -module and as a right K_Γ -module.*

Proof. As a left K_Λ -module, we have that $K_{\Lambda\Gamma}^t \cong \bigoplus_{\gamma \in \Gamma} K_{\Lambda\Gamma}^t e_\gamma$. Each summand is projective by Theorem 4.2(i),(iii), hence $K_{\Lambda\Gamma}^t$ is a projective left K_Λ -module. Moreover, by the anti-multiplicativity of $*$, we know that $K_{\Lambda\Gamma}^t$ is isomorphic as a right K_Γ -module to the right K_Γ -module obtained by twisting the left K_Γ -module $K_{\Gamma\Lambda}^{t*}$ with $*$. As we have already established, $K_{\Gamma\Lambda}^{t*}$ is a projective left K_Γ -module, hence $K_{\Lambda\Gamma}^t$ is a projective right K_Γ -module too. \square

Corollary 4.4. *Projective functors are exact and send finitely generated projectives to finitely generated projectives.*

Filtrations by cell modules. Recall the definition of the *cell modules* $V(\mu)$ for K_Λ from [BS, §5]: for each $\mu \in \Lambda$, $V(\mu)$ is the graded vector space with homogeneous basis $\{(c\mu| \mid \text{for all oriented cup diagrams } c\mu\}$ and the action of $(a\lambda b) \in K_\Lambda$ is defined by

$$(a\lambda b)(c\mu| := \begin{cases} s_{a\lambda b}(\mu)(a\mu| & \text{if } b^* = c \text{ and } a\mu \text{ is oriented,} \\ 0 & \text{otherwise,} \end{cases} \quad (4.2)$$

where $s_{a\lambda b}(\mu) \in \{0, 1\}$ is the scalar from [BS, Theorem 4.4]. The following theorem describes explicitly the effect of a projective functor on a cell module, showing in particular that a cell module is mapped to a module with a multiplicity-free filtration by cell modules.

Theorem 4.5. *Let t be a proper $\Lambda\Gamma$ -matching and $\gamma \in \Gamma$.*

(i) *The K_Λ -module $G_{\Lambda\Gamma}^t V(\gamma)$ has a filtration*

$$\{0\} = M(0) \subset M(1) \subset \cdots \subset M(n) = G_{\Lambda\Gamma}^t V(\gamma)$$

such that $M(i)/M(i-1) \cong V(\mu_i)\langle \deg(\mu_i t\gamma) - \text{caps}(t) \rangle$ for each i . Here μ_1, \dots, μ_n denote the elements of the set $\{\mu \in \Lambda \mid \mu t\gamma \text{ is oriented}\}$ ordered so that $\mu_i > \mu_j$ implies $i < j$.

(ii) *The module $G_{\Lambda\Gamma}^t V(\gamma)$ is non-zero if and only if each cup in $t\gamma$ is oriented (some could be clockwise and some anti-clockwise).*

(iii) *Assuming the condition in (ii) is satisfied, the module $G_{\Lambda\Gamma}^t V(\gamma)$ is indecomposable with irreducible head isomorphic to $L(\lambda)\langle \deg(\lambda t\gamma) - \text{caps}(t) \rangle$, where $\lambda \in \Lambda$ is the unique weight such that $\bar{\lambda}$ is the upper reduction of $t\bar{\gamma}$; equivalently, $\lambda t\gamma$ is oriented and all its caps are anti-clockwise.*

Proof. We first claim that the vectors

$$\{(a\mu_i t\gamma\bar{\gamma}) \otimes (\underline{\gamma}\gamma| \mid \text{for } i = 1, \dots, n \text{ and all oriented cup diagrams } a\mu_i\}$$

give a basis for $G_{\Lambda\Gamma}^t V(\gamma)$. By Theorem 3.5(ii), the vectors $(a\mu t\nu\bar{\nu}) \otimes (\underline{\nu}\nu\bar{\nu})$ give a basis for $G_{\Lambda\Gamma}^t P(\gamma)$. By [BS, Theorem 5.1], $V(\gamma)$ is the quotient of $P(\gamma)$ by the subspace spanned by the vectors $(c\nu\bar{\nu})$ for $\nu > \gamma$. Using exactness of the functor $G_{\Lambda\Gamma}^t$, it follows that $G_{\Lambda\Gamma}^t V(\gamma)$ is the quotient of $G_{\Lambda\Gamma}^t P(\gamma)$ by the subspace spanned by the vectors $(a\mu t\lambda b) \otimes (c\nu\bar{\nu})$ for $\nu > \gamma$. By Theorem 3.5(i), this subspace is spanned already by the basis vectors $(a\mu t\nu\bar{\nu}) \otimes (\underline{\nu}\nu\bar{\nu})$ for $\nu > \gamma$. Hence $G_{\Lambda\Gamma}^t V(\gamma)$ has a basis given by the images of the vectors $(a\mu t\gamma\bar{\gamma}) \otimes (\underline{\gamma}\gamma\bar{\gamma})$, which is equivalent to the claim.

Now we let $M(0) := \{0\}$ and for $i = 1, \dots, n$ let $M(i)$ be the subspace of $G_{\Lambda\Gamma}^t V(\gamma)$ generated by $M(i-1)$ and the vectors

$$\{(a\mu_i t\gamma\bar{\gamma}) \otimes (\underline{\gamma}\gamma| \mid \text{for all oriented cup diagrams } a\mu_i\}.$$

Thanks to the previous paragraph, this defines a filtration of $G_{\Lambda\Gamma}^t V(\gamma)$ with $M(n) = G_{\Lambda\Gamma}^t V(\gamma)$. We observe moreover that each $M(i)$ is a K_Λ -submodule of $G_{\Lambda\Gamma}^t V(\gamma)$. This follows by Corollary 3.4 and Theorem 3.5(i). The quotient $M(i)/M(i-1)$ has basis given by the images of the vectors

$$\{(c\mu_i t\gamma\bar{\gamma}) \otimes (\underline{\gamma}\gamma| \mid \text{for all oriented cup diagrams } c\mu_i\}.$$

Moreover by Theorem 3.3 we have that

$$(a\lambda b)(c\mu_i t\gamma\bar{\gamma}) \otimes (\underline{\gamma\gamma}) \equiv \begin{cases} s_{a\lambda b}(\mu_i)(a\mu_i t\gamma\bar{\gamma}) \otimes (\underline{\gamma\gamma}) & \text{if } b = c^* \text{ and } a\mu_i \text{ is oriented,} \\ 0 & \text{otherwise,} \end{cases}$$

working modulo $M(i-1)$. Recalling (4.2), it follows that the map

$$M(i)/M(i-1) \rightarrow V(\mu_i)\langle \deg(\mu_i t\gamma) - \text{caps}(t) \rangle, \quad (c\mu_i t\gamma\bar{\gamma}) \otimes (\underline{\gamma\gamma}) \mapsto (c\mu_i |$$

is an isomorphism of graded K_Λ -modules. This proves (i).

Now we deduce (ii). If there is a cup in the diagram $t\gamma$ that is not oriented, then there are no $\mu \in \Lambda$ such that $\mu t\gamma$ is oriented. Hence $G_{\Lambda\Gamma}^t V(\gamma) = \{0\}$ by (i). Conversely, if every cup in $t\gamma$ is oriented, then the weight λ defined in the statement of (iii) is a weight such that $\lambda t\gamma$ is oriented, hence $G_{\Lambda\Gamma}^t V(\gamma)$ is non-zero.

Finally to prove (iii), we ignore the grading for a while. The cell filtration from (ii) is multiplicity-free. Since each cell module has irreducible head, it follows easily that $G_{\Lambda\Gamma}^t V(\gamma)$ has multiplicity-free head. On the other hand, $G_{\Lambda\Gamma}^t V(\gamma)$ is a quotient of $G_{\Lambda\Gamma}^t P(\gamma)$, which by Theorem 4.2(iii) is a direct sum of copies of $P(\lambda)$. Hence the head of $G_{\Lambda\Gamma}^t V(\gamma)$ is a direct sum of copies of $L(\lambda)$. These two facts together imply that the head consists of just one copy of $L(\lambda)$ (shifted by some degree). It just remains to determine the degree shift, which follows from (i). \square

Adjunctions. Let t be a proper $\Lambda\Gamma$ -matching. We are going to prove that the functors $G_{\Gamma\Lambda}^{t^*}$ and $G_{\Lambda\Gamma}^t$ form an adjoint pair (up to some degree shifts). Define a linear map

$$\varphi : K_{\Gamma\Lambda}^{t^*} \otimes K_{\Lambda\Gamma}^t \rightarrow K_\Gamma \quad (4.3)$$

as follows. If t is not a proper $\Lambda\Gamma$ -matching we simply take $\varphi := 0$. Now assume that t is proper and take basis vectors $(a\lambda t^* \nu d) \in K_{\Gamma\Lambda}^{t^*}$ and $(d' \kappa t \mu b) \in K_{\Lambda\Gamma}^t$. Let c be the upper reduction of t^*d . If $d' = d^*$ and all mirror image pairs of upper and lower circles in t^*d and d^*t , respectively, are oriented in *opposite* ways in the diagrams $a\lambda t^* \nu d$ and $d^* \kappa t \mu b$ then we set

$$\varphi((a\lambda t^* \nu d) \otimes (d' \kappa t \mu b)) := (a\lambda c)(c^* \mu b) \quad (4.4)$$

Otherwise, we set

$$\varphi((a\lambda t^* \nu d) \otimes (d' \kappa t \mu b)) := 0. \quad (4.5)$$

Lemma 4.6. *The map $\varphi : K_{\Gamma\Lambda}^{t^*} \otimes K_{\Lambda\Gamma}^t \rightarrow K_\Gamma$ is a homogeneous (K_Γ, K_Γ) -bimodule homomorphism of degree $-2 \text{ caps}(t)$. Moreover it is K_Λ -balanced, so it factors through the quotient to induce a map $\bar{\varphi} : K_{\Gamma\Lambda}^{t^*} \otimes_{K_\Lambda} K_{\Lambda\Gamma}^t \rightarrow K_\Gamma$.*

Proof. We may as well assume that t is a proper $\Lambda\Gamma$ -matching, as the lemma is trivial if it is not. Now we proceed in several steps.

Step one: φ is homogeneous of degree $-2 \text{ caps}(t)$. To see this, let notation be as in (4.4). Suppose p (resp. q) of the upper circles in t^*d are clockwise (resp.

anti-clockwise) in the diagram $a\lambda t^*\nu d$. Then q (resp. p) of the lower circles in d^*t are clockwise (resp. anti-clockwise). By Lemma 2.4 we have that

$$\begin{aligned}\deg(a\lambda t^*\nu d) &= \deg(a\lambda c) + \text{cups}(t^*) + p - q, \\ \deg(d^*\kappa t\mu b) &= \deg(c^*\mu b) + \text{caps}(t) + q - p.\end{aligned}$$

Noting $\text{cups}(t^*) = \text{caps}(t)$, this shows that

$$\deg((a\lambda c)(c^*\mu b)) = \deg((a\lambda t^*\nu d) \otimes (d^*\kappa t\mu b)) - 2\text{caps}(t).$$

Step two: the analogous statement at the level of Khovanov algebras. Assume that Λ and Γ are Khovanov blocks. Then we can also define a linear map

$$\psi : H_{\Gamma\Lambda}^{t^*} \otimes H_{\Lambda\Gamma}^t \rightarrow H_{\Gamma}$$

by exactly the same formulae (4.4)–(4.5) that were used to define φ . We are going to prove that ψ is an (H_{Γ}, H_{Γ}) -bimodule homomorphism and an H_{Λ} -balanced map. To see this, it is quite obvious from the definition that ψ is a left H_{Γ} -module homomorphism, since only the circles that do not meet the bottom number line get changed in the passage from $a\lambda t^*\nu d$ to $a\lambda c$, and these play no role in the left H_{Γ} -module structure. Similarly, ψ is a right H_{Γ} -module homomorphism. It remains to prove that ψ is H_{Λ} -balanced. Introduce a new map

$$\omega : H_{\Gamma\Lambda\Gamma}^{t^*t} \rightarrow H_{\Gamma}$$

as follows. Take a basis vector $(a\lambda t^*\mu t\nu b) \in H_{\Gamma\Lambda\Gamma}^{t^*t}$. If any of the internal circles in the diagram t^*t are anti-clockwise in $a\lambda t^*\mu t\nu b$, we map it to zero. Otherwise, let u be the reduction of t^*t and consider the diagram $a\lambda u\nu b$. This has a symmetric middle section containing u so it makes sense to iterate the surgery procedure from [BS, §3] to this middle section to obtain a linear combination of basis vectors of H_{Γ} . We define the image of $(a\lambda t^*\mu t\nu b)$ under the map ω to be this linear combination. The main task now is to prove that

$$\psi = \omega \circ m, \tag{4.6}$$

where m denotes the multiplication map $H_{\Gamma\Lambda}^{t^*} \otimes H_{\Lambda\Gamma}^t \rightarrow H_{\Gamma\Lambda\Gamma}^{t^*t}$ from (3.3). Since we know by (3.4) that m is H_{Λ} -balanced, (4.6) immediately implies that ψ is H_{Λ} -balanced.

To prove (4.6), take basis vectors $(a\lambda t^*\nu d) \in H_{\Gamma\Lambda}^{t^*}$ and $(d'\kappa t\mu b) \in H_{\Lambda\Gamma}^t$. Since both maps ψ and m are zero on $(a\lambda t^*\nu d) \otimes (d'\kappa t\mu b)$ if $d' \neq d^*$, we may assume $d' = d^*$. Now we proceed to show that

$$\psi((a\lambda t^*\nu d) \otimes (d^*\kappa t\mu b)) = \omega((a\lambda t^*\nu d)(d^*\kappa t\mu b)) \tag{4.7}$$

by induction on $\text{caps}(t)$. In the base case $\text{caps}(t) = 0$, there are no upper circles in t^*d and no internal circles in the diagram t^*t . Moreover, there is a natural bijection between the caps in the diagram t^*d and the caps in its upper reduction c . To compute $\psi((a\lambda t^*\nu d) \otimes (d^*\kappa t\mu b)) = (a\lambda c)(c^*\mu b)$ involves applying the surgery procedure to eliminate each of these caps in turn. On the other hand, to compute $\omega((a\lambda t^*\nu d)(d^*\kappa t\mu b))$ involves first applying the surgery procedure to eliminate all of the caps in d (that is what the multiplication m does) then applying it some more to eliminate the remaining caps in t^* (that is what ω does). The result is clearly the same either way.

So now assume that $\text{caps}(t) > 0$ and that (4.7) has been proved for all smaller cases. Suppose first that the diagram t^*d contains a small circle (a circle with just one cup and cap). If this circle and its mirror image are oriented in the same ways in $t^*\nu d$ and $d^*\kappa t$ then ψ produces zero. If they are both clockwise circles then the product $(a\lambda t^*\nu d)(d^*\kappa t\mu b)$ is zero, and if they are both anti-clockwise circles then there is an anti-clockwise internal circle in the product $(a\lambda t^*\nu d)(d^*\kappa t\mu b)$ so ω produces zero. Hence we may assume the small circle and its mirror image are oriented in opposite ways in $t^*\nu d$ and $d^*\kappa t$. Now we can just remove these two circles (and the vertices they pass through on the number lines) to obtain simpler diagrams $a\lambda t_1^*\nu_1 d_1$ and $d_1^*\kappa_1 t_1 \mu b$ with $\text{caps}(t_1) < \text{caps}(t)$. Using the definitions it is easy to see that

$$\begin{aligned}\psi((a\lambda t^*\nu d) \otimes (d^*\kappa t\mu b)) &= \psi((a\lambda t_1^*\nu_1 d_1) \otimes (d_1^*\kappa_1 t_1 \mu b)), \\ \omega((a\lambda t^*\nu d)(d^*\kappa t\mu b)) &= \omega((a\lambda t_1^*\nu_1 d_1)(d_1^*\kappa_1 t_1 \mu b)).\end{aligned}$$

By induction the right hand sides of these equations are equal. Hence the left hand sides are equal too.

We are now reduced to the situation that $\text{caps}(t) > 0$ and t^*d contains no small circles. Then there must be a kink on the top number line of t^*d with a mirror image kink in d^*t . Let $a\lambda t_1^*\nu_1 d_1$ and $d_1^*\kappa_1 t_1 \mu b$ be the diagrams obtained by straightening these kinks (removing two vertices from the number lines in the process):

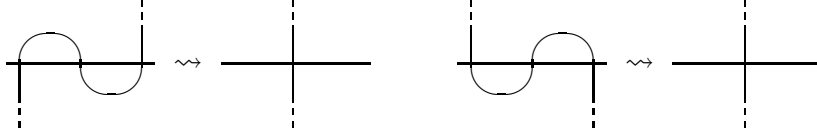

Again we have that $\text{caps}(t_1) < \text{caps}(t)$ so are done by the induction hypothesis as soon as we can show that

$$\begin{aligned}\psi((a\lambda t^*\nu d) \otimes (d^*\kappa t\mu b)) &= \psi((a\lambda t_1^*\nu_1 d_1) \otimes (d_1^*\kappa_1 t_1 \mu b)), \\ \omega((a\lambda t^*\nu d)(d^*\kappa t\mu b)) &= \omega((a\lambda t_1^*\nu_1 d_1)(d_1^*\kappa_1 t_1 \mu b)).\end{aligned}$$

The first equality is clear as t^*d and $t_1^*d_1$ have the same upper reduction c . To get the second equality, observe to compute the product $(a\lambda t^*\nu d)(d^*\kappa t\mu b)$ we can follow exactly the same sequence of surgery procedures as to compute $(a\lambda t_1^*\nu_1 d_1)(d_1^*\kappa_1 t_1 \mu b)$ then add one additional surgery procedure at the end involving the kinks that were removed. This final surgery procedure creates one extra internal circle:

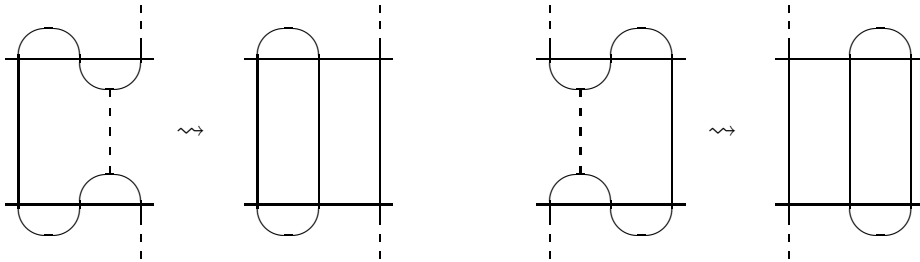

Since ω sends anti-clockwise internal circles to zero, we are only interested in terms in which this extra internal circle is clockwise, so that the other circle gets oriented at the end in the same way as it was prior to the last surgery procedure.

We conclude that the terms in the product $(a\lambda t^* \nu d)(d^* \kappa t \mu b)$ in which the extra circle is clockwise exactly match the terms in the product $(a\lambda t_1^* \nu_1 d_1)(d_1^* \kappa_1 t_1 \mu b)$. So ω takes the same value on them both.

Step three: φ is a K_Λ -balanced (K_Γ, K_Γ) -bimodule homomorphism. It remains to deduce this statement about φ from the analogous statement about ψ at the level of Khovanov algebras just established in step two. This is done by reducing first to the case that Γ and Λ are blocks of bounded weights by a direct limit argument involving (3.11), then passing from there to the Khovanov algebra setting by taking closures using (3.10). We omit the details. (It is also possible to give a direct proof of this statement by mimicing the arguments from step two in terms of the generalised surgery procedure from [BS, §6].) \square

Theorem 4.7. *There is a graded (K_Λ, K_Γ) -bimodule isomorphism*

$$\hat{\varphi} : K_{\Lambda\Gamma}^t \langle -2 \text{ caps}(t) \rangle \xrightarrow{\sim} \text{Hom}_{K_\Gamma}(K_{\Gamma\Lambda}^{t*}, K_\Gamma)$$

sending $y \in K_{\Lambda\Gamma}^t$ to the homomorphism $\hat{\varphi}(y) : K_{\Gamma\Lambda}^{t*} \rightarrow K_\Gamma, x \mapsto \varphi(x \otimes y)$.

Proof. We know already that φ is of degree $-2 \text{ caps}(t)$ by Lemma 4.6, hence the map $\hat{\varphi}$ is homogeneous of degree 0. To check it is a left K_Λ -module homomorphism, take $u \in K_\Lambda, y \in K_{\Lambda\Gamma}^t$ and $x \in K_{\Gamma\Lambda}^{t*}$. Using the fact that φ is K_Λ -balanced, we get that

$$(u\hat{\varphi}(y))(x) = \hat{\varphi}(y)(xu) = \varphi(xu \otimes y) = \varphi(x \otimes uy) = \hat{\varphi}(uy)(x).$$

Hence $u\hat{\varphi}(y) = \hat{\varphi}(uy)$ as required. To check that it is a right K_Γ -module homomorphism suppose also that $v \in K_\Gamma$. Then

$$(\hat{\varphi}(y)v)(x) = (\hat{\varphi}(y)(x))v = \varphi(x \otimes y)v = \varphi(x \otimes yv) = \hat{\varphi}(yv)(x).$$

So $\hat{\varphi}(y)v = \hat{\varphi}(yv)$ as required. It remains to check that $\hat{\varphi}$ is a vector space isomorphism. For this it is sufficient to show that the restriction

$$\hat{\varphi} : e_\lambda K_{\Lambda\Gamma}^t \rightarrow e_\lambda \text{Hom}_{K_\Gamma}(K_{\Gamma\Lambda}^{t*}, K_\Gamma) = \text{Hom}_{K_\Gamma}(K_{\Gamma\Lambda}^{t*} e_\lambda, K_\Gamma)$$

is an isomorphism for each $\lambda \in \Lambda$. We may as well assume that $e_\lambda K_{\Lambda\Gamma}^t$ is non-zero, since this is equivalent to $K_{\Gamma\Lambda}^{t*} e_\lambda$ being non-zero. Let $\gamma \in \Gamma$ be defined so that $\bar{\gamma}$ is the upper reduction of $t^* \bar{\lambda}$. Let n be the number of upper circles removed in the reduction process. Then by Theorem 4.2(i),(iii) we have that $K_{\Gamma\Lambda}^{t*} e_\lambda \cong K_\Gamma e_\gamma \otimes R^{\otimes n}$ as a left K_Γ -module (for the rest of the proof we are ignoring the grading). Similarly, $e_\lambda K_{\Lambda\Gamma}^t \cong e_\gamma K_\Gamma \otimes R^{\otimes n}$ as right K_Γ -modules. Transporting the map $\hat{\varphi}$ through these isomorphisms, the thing we are trying to prove is equivalent to showing that the map

$$\begin{aligned} e_\gamma K_\Gamma \otimes R^{\otimes n} &\rightarrow \text{Hom}_{K_\Gamma}(K_\Gamma e_\gamma \otimes R^{\otimes n}, K_\Gamma), \\ v \otimes x_1 \otimes \cdots \otimes x_n &\mapsto (u \otimes y_1 \otimes \cdots \otimes y_n \mapsto \tau(x_1 y_1) \cdots \tau(x_n y_n)) uv \end{aligned}$$

is an isomorphism, where τ is the counit from (3.16). This quickly reduces to checking that the natural map $e_\gamma K_\Gamma \rightarrow \text{Hom}_{K_\Gamma}(K_\Gamma e_\gamma, K_\Gamma)$ defined by right multiplication is an isomorphism, which is well known. \square

Corollary 4.8. *There is a canonical isomorphism*

$$\text{Hom}_{K_\Gamma}(K_{\Gamma\Lambda}^{t*}, ?) \cong K_{\Lambda\Gamma}^t \langle -2 \text{ caps}(t) \rangle \otimes_{K_\Gamma} ?$$

of functors from $\text{Mod}_f(K_\Gamma)$ to $\text{Mod}_f(K_\Lambda)$.

Proof. There is an obvious natural homomorphism

$$\text{Hom}_{K_\Gamma}(K_{\Gamma\Lambda}^{t*}, M) \cong \text{Hom}_{K_\Gamma}(K_{\Gamma\Lambda}^{t*}, K_\Gamma) \otimes_{K_\Gamma} M$$

for any K_Γ -module M . Since $K_{\Gamma\Lambda}^{t*}$ is a projective left K_Γ -module, it is actually an isomorphism. Now compose with the inverse of the bimodule isomorphism from Theorem 4.7. \square

Corollary 4.9. *There is a canonical degree zero adjunction making*

$$(G_{\Gamma\Lambda}^{t*} \langle \text{cups}(t) - \text{caps}(t) \rangle, G_{\Lambda\Gamma}^t)$$

into an adjoint pair of functors between $\text{Mod}_f(K_\Lambda)$ and $\text{Mod}_f(K_\Gamma)$.

Proof. Combine the standard adjunction making $(K_{\Gamma\Lambda}^{t*} \otimes_{K_\Lambda} ?, \text{Hom}_{K_\Gamma}(K_{\Gamma\Lambda}^{t*}, ?))$ into an adjoint pair with Corollary 4.8, and recall the degree shift in (4.1). \square

Projective functors commute with duality. Next we show that projective functors commute with the \otimes duality introduced just before [BS, (5.4)].

Theorem 4.10. *For a proper $\Lambda\Gamma$ -matching t and any graded K_Γ -module M , there is a natural isomorphism $G_{\Lambda\Gamma}^t(M^\otimes) \cong (G_{\Lambda\Gamma}^t M)^\otimes$ of graded K_Λ -modules.*

Proof. In view of the grading shift in (4.1), it suffices to construct a natural K_Λ -module isomorphism

$$K_{\Lambda\Gamma}^t \otimes_{K_\Gamma} (M^\otimes) \xrightarrow{\sim} (K_{\Lambda\Gamma}^t \otimes_{K_\Gamma} M)^\otimes$$

that is homogeneous of degree $-2 \text{caps}(t)$.

We first define a linear map

$$\theta : K_{\Lambda\Gamma}^t \otimes (M^\otimes) \otimes K_{\Lambda\Gamma}^t \otimes M \rightarrow \mathbb{F}$$

by sending $x \otimes f \otimes y \otimes m$ to $f(\varphi(x^* \otimes y)m)$, where φ is the map from (4.3) and $*$ is the degree preserving map from (3.9). Since φ is of degree $-2 \text{caps}(t)$ according to Lemma 4.6, the map θ is of degree $-2 \text{caps}(t)$ as well. For $u \in K_\Gamma$, we have that

$$\begin{aligned} \theta(xu \otimes f \otimes y \otimes m) &= f(\varphi((xu)^* \otimes y)m) = f(\varphi(u^*x^* \otimes y)m) \\ &= f(u^*\varphi(x^* \otimes y)m) = (uf)(\varphi(x^* \otimes y)m) = \theta(x \otimes uf \otimes y \otimes m) \end{aligned}$$

and

$$\begin{aligned} \theta(x \otimes f \otimes yu \otimes m) &= f(\varphi(x^* \otimes yu)m) \\ &= f(\varphi(x^* \otimes y)um) = \theta(x \otimes f \otimes y \otimes um). \end{aligned}$$

This shows that θ factors through the quotients to induce a homogeneous linear map $(K_{\Lambda\Gamma}^t \otimes_{K_\Gamma} (M^\otimes)) \otimes (K_{\Lambda\Gamma}^t \otimes_{K_\Gamma} M) \rightarrow \mathbb{F}$ of degree $-2 \text{caps}(t)$.

Hence there is a well-defined homogeneous linear map of degree $-2 \text{caps}(t)$

$$\tilde{\theta} : K_{\Lambda\Gamma}^t \otimes_{K_\Gamma} (M^\otimes) \rightarrow (K_{\Lambda\Gamma}^t \otimes_{K_\Gamma} M)^\otimes$$

which sends a generator $x \otimes f \in K_{\Lambda\Gamma}^t \otimes_{K_\Gamma} (M^\otimes)$ to the function

$$\begin{aligned} \tilde{\theta}(x \otimes f) : K_{\Lambda\Gamma}^t \otimes_{K_\Gamma} M &\rightarrow \mathbb{F}, \\ y \otimes m &\mapsto \theta(x \otimes f \otimes y \otimes m) = f(\varphi(x^* \otimes y)m). \end{aligned}$$

We check moreover that $\tilde{\theta}$ is a K_Λ -module homomorphism: for $v \in K_\Lambda$ we have that

$$\begin{aligned} (v\tilde{\theta}(x \otimes f))(y \otimes m) &= (\tilde{\theta}((x) \otimes f))(v^*y \otimes m) = f(\varphi(x^* \otimes v^*y)m) \\ &= f(\varphi(x^*v^* \otimes y)m) = f(\varphi((vx)^* \otimes y)m) \\ &= \tilde{\theta}(vx \otimes f)(y \otimes m), \end{aligned}$$

i.e. $v\tilde{\theta}(x \otimes f) = \tilde{\theta}(vx \otimes f)$.

It remains to prove that $\tilde{\theta}$ is a vector space isomorphism. For this, it suffices to show for each $\lambda \in \Lambda$ that the restriction

$$\tilde{\theta} : e_\lambda K_{\Lambda\Gamma}^t \otimes_{K_\Gamma} (M^\otimes) \rightarrow e_\lambda (K_{\Lambda\Gamma}^t \otimes_{K_\Gamma} M)^\otimes.$$

is an isomorphism. Of course we can identify $e_\lambda (K_{\Lambda\Gamma}^t \otimes_{K_\Gamma} M)^\otimes$ with the graded dual $(e_\lambda K_{\Lambda\Gamma}^t \otimes_{K_\Gamma} M)^\otimes$ of the vector space $e_\lambda K_{\Lambda\Gamma}^t \otimes_{K_\Gamma} M$. We may as well assume that $e_\lambda K_{\Lambda\Gamma}^t \neq \{0\}$. Let $\gamma \in \Gamma$ be defined so that $\bar{\gamma}$ is the upper reduction of $t^*\bar{\lambda}$. Let n be the number of upper circles removed in the reduction process. Then by Theorem 4.2(i),(iii) we have that

$$e_\lambda K_{\Lambda\Gamma}^t \cong e_\gamma K_\Gamma \otimes R^{\otimes n}$$

as right K_Γ -modules (ignoring gradings). Transporting $\tilde{\theta}$ through this isomorphism, our problem reduces to showing that the map

$$(e_\gamma K_\Gamma \otimes_{K_\Gamma} (M^\otimes)) \otimes R^{\otimes n} \rightarrow ((e_\gamma K_\Gamma \otimes_{K_\Gamma} M) \otimes R^{\otimes n})^\otimes$$

that sends $(u \otimes f) \otimes x_1 \otimes \cdots \otimes x_n$ to the function $(v \otimes m) \otimes y_1 \otimes \cdots \otimes y_n \mapsto \tau(x_1 y_1) \cdots \tau(x_n y_n) f(u^* v m)$ is an isomorphism, where τ denotes the counit from (3.16). To see this, identify $e_\gamma K_\Gamma \otimes_{K_\Gamma} M = e_\gamma M$ and $e_\gamma K_\Gamma \otimes_{K_\Gamma} (M^\otimes) = e_\gamma (M^\otimes) = (e_\gamma M)^\otimes$. \square

Projective functors on irreducible modules. The next theorem describes the effect of projective functors on the irreducible K_Γ -modules $\{L(\gamma) \mid \gamma \in \Gamma\}$; recall in Theorems 4.2 and 4.5 we already explained what they do to projective and cell modules.

Theorem 4.11. *Let t be a proper $\Lambda\Gamma$ -matching and $\gamma \in \Gamma$.*

(i) *In the graded Grothendieck group $[\text{Mod}_f(K_\Lambda)]$, we have that*

$$[G_{\Lambda\Gamma}^t L(\gamma)] = \sum_{\mu} (q + q^{-1})^{n_\mu} [L(\mu)],$$

where n_μ denotes the number of lower circles in $\underline{\mu}t$ and the sum is over all $\mu \in \Lambda$ such that

- (a) $\underline{\gamma}$ is the lower reduction of $\underline{\mu}t$;
 - (b) the rays of each lower line in $\underline{\mu}t$ are oriented so that exactly one is \wedge and one is \vee .
- (ii) *The module $G_{\Lambda\Gamma}^t L(\gamma)$ is non-zero if and only if the cups of $t\gamma$ are oriented so they are all anti-clockwise.*
- (iii) *Assuming the condition in (ii) is satisfied, define $\lambda \in \Lambda$ by declaring that $\bar{\lambda}$ is the upper reduction of $t\bar{\gamma}$; equivalently, $\lambda t\gamma$ is oriented and all*

its caps and cups are anti-clockwise. Then $G_{\Lambda\Gamma}^t L(\gamma)$ is a self-dual indecomposable module with irreducible head isomorphic to $L(\lambda)\langle -\text{caps}(t) \rangle$.

Proof. We first prove (i). We need to show for any $\mu \in \Lambda$ that

$$(\dagger) := \sum_{j \in \mathbb{Z}} q^j \dim \text{Hom}_{K_\Lambda}(P(\mu), G_{\Lambda\Gamma}^t L(\gamma))_j$$

is non-zero if and only if the conditions (a) and (b) are satisfied, when it equals $(q + q^{-1})^{n_\mu}$. By Corollary 4.9 we have that

$$(\dagger) = \sum_{j \in \mathbb{Z}} q^j \dim \text{Hom}_{K_\Gamma}(G_{\Gamma\Lambda}^{t*} P(\mu)\langle \text{cups}(t) - \text{caps}(t) \rangle, L(\gamma))_j.$$

By Theorem 4.2 we know that $G_{\Gamma\Lambda}^{t*} P(\mu)$ is non-zero if and only if (b) is satisfied, in which case it is isomorphic to $P(\beta) \otimes R^{\otimes n_\mu} \langle \text{caps}(t) - \text{caps}(t) \rangle$ where $\beta \in \Gamma$ is such that the lower reduction of $\underline{\mu}t$ equals $\underline{\beta}$. Hence (\dagger) is non-zero if and only if both (a) and (b) are satisfied, in which case

$$(\dagger) = \sum_{j \in \mathbb{Z}} q^j \dim \text{Hom}_{K_\Gamma}(P(\gamma) \otimes R^{\otimes n_\mu}, L(\gamma))_j = (q + q^{-1})^{n_\mu},$$

as claimed.

Now we deduce (ii) and (iii). As $G_{\Lambda\Gamma}^t L(\gamma)$ is a quotient of $G_{\Lambda\Gamma}^t V(\gamma)$, we may assume by Theorem 4.5(ii) that each cup of $t\gamma$ is oriented. By Theorem 4.5(iii), $G_{\Lambda\Gamma}^t V(\gamma)$ has irreducible head $L(\lambda)\langle \text{deg}(\lambda t\gamma) - \text{caps}(t) \rangle$. Hence $G_{\Lambda\Gamma}^t L(\gamma)$ is either zero or else it too has irreducible head $L(\lambda)\langle \text{deg}(\lambda t\gamma) - \text{caps}(t) \rangle$. But we know already by (i) that $G_{\Lambda\Gamma}^t L(\gamma)$ has a composition factor isomorphic to $L(\lambda)$ (shifted in degree) if and only if the weight $\mu := \lambda$ satisfies the conditions (a) and (b) from (i). In view of the definition of λ , these conditions are equivalent simply to the assertion that each cup of $t\gamma$ is anti-clockwise, i.e. $\text{deg}(\lambda t\gamma) = 0$. We have now proved (ii), and moreover we have established the statement from (iii) about the head. Finally the fact that $G_{\Lambda\Gamma}^t L(\gamma)$ is self-dual follow from Theorem 4.10. \square

Corollary 4.12. *The functor $G_{\Lambda\Gamma}^t$ sends finite dimensional modules to finite dimensional modules.*

Proof. In view of the theorem, it remains to observe for $\gamma \in \Gamma$ that there are only finitely many $\lambda \in \Lambda$ such that $\underline{\lambda}$ is the lower reduction of $\underline{\lambda}t$. This follows ultimately because there are only finitely many caps in t . \square

Indecomposable projective functors. The final theorem of the section proves that the projective functor from (4.1) is an indecomposable functor, i.e. it cannot be written as the direct sum of two non-zero subfunctors. The proof follows the same strategy as the proof of [S2, Theorem 5.1]. We need one preliminary lemma. To formulate this, let t be a proper $\Lambda\Gamma$ -matching. Define

$$\Gamma(t) := \{\gamma \in \Gamma \mid K_{\Lambda\Gamma}^t \otimes_{K_\Gamma} L(\gamma) \neq \{0\}\}. \quad (4.8)$$

Note Theorem 4.11(ii) gives an explicit combinatorial description of $\Gamma(t)$: it is the set of all weights $\gamma \in \Gamma$ such that all cups in the composite diagram $t\gamma$ are anti-clockwise cups. Let $\overset{t}{\sim}$ denote the equivalence relation on $\Gamma(t)$ generated

by the property that $\lambda \overset{t}{\sim} \mu$ if the composition multiplicity $[V(\lambda) : L(\mu)]$ is non-zero, for $\lambda, \mu \in \Gamma(t)$.

Lemma 4.13. *The set $\Gamma(t)$ is a single $\overset{t}{\sim}$ -equivalence class.*

Proof. Let I index the vertices on the top number line of t that are at the ends of line segments. Take any pair of indices $i < j$ from I that are neighbours in the sense that no integer between i and j belongs to I . To prove the lemma it suffices to show that $\lambda \sim \mu$ for any pair of weights $\lambda, \mu \in \Gamma(t)$ such that

- ▶ the i th and j th vertices of λ and μ are labelled $\wedge\vee$ and $\vee\wedge$, respectively;
- ▶ all other vertices of λ and μ are labelled in the same way.

For this, note from the explicit combinatorial description of weights in $\Gamma(t)$ that $\underline{\mu}$ has a cup joining vertices i and j . Hence $\underline{\mu}\lambda$ is an oriented cup diagram. It follows that $[V(\lambda) : L(\mu)] \neq 0$ by [BS, Theorem 5.2], so $\lambda \overset{t}{\sim} \mu$ as required. \square

Theorem 4.14. *The functor $G_{\Lambda\Gamma}^t : \text{Mod}_f(K_\Gamma) \rightarrow \text{Mod}_f(K_\Lambda)$ is indecomposable.*

Proof. Suppose that $G_{\Lambda\Gamma}^t = F_1 \oplus F_2$ as a direct sum of functors. Each F_i is automatically exact. To prove the theorem it suffices to show either that $F_1 = 0$ or that $F_2 = 0$. By exactness, this follows if we can show either that $\Gamma_1 = \emptyset$ or that $\Gamma_2 = \emptyset$, where $\Gamma_i := \{\gamma \in \Gamma \mid F_i L(\gamma) \neq \{0\}\}$.

Take $\gamma \in \Gamma$. If $\gamma \notin \Gamma(t)$ then $G_{\Lambda\Gamma}^t L(\gamma) = \{0\}$, hence both $F_1 L(\gamma)$ and $F_2 L(\gamma)$ are zero. If $\gamma \in \Gamma(t)$ then $G_{\Lambda\Gamma}^t L(\gamma) = F_1 L(\gamma) \oplus F_2 L(\gamma)$ is a non-zero indecomposable module by Theorem 4.11(iii). Hence exactly one of $F_1 L(\gamma)$ or $F_2 L(\gamma)$ is non-zero. This shows that we have a partition

$$\Gamma(t) = \Gamma_1 \sqcup \Gamma_2.$$

Now we claim for weights $\lambda, \mu \in \Gamma(t)$ satisfying $[V(\lambda) : L(\mu)] \neq 0$ that λ and μ belong to the same one of the sets Γ_1 or Γ_2 . To see this, assume without loss of generality that $\lambda \in \Gamma_1$. As $F_1 L(\lambda) \neq \{0\}$ we deduce that $F_1 V(\lambda) \neq \{0\}$. As $G_{\Lambda\Gamma}^t V(\lambda) = F_1 V(\lambda) \oplus F_2 V(\lambda)$ is indecomposable by Theorem 4.5(iii), we deduce that $F_2 V(\lambda) = \{0\}$. As $[V(\lambda) : L(\mu)] \neq 0$ we deduce that $F_2 L(\mu) = \{0\}$ too. Hence $\mu \notin \Gamma_2$, so $\mu \in \Gamma_1$ as required.

Recalling the definition of the equivalence relation $\overset{t}{\sim}$ on $\Gamma(t)$, the previous paragraph shows that Γ_1 and Γ_2 are both unions of $\overset{t}{\sim}$ -equivalence classes. In view of Lemma 4.13 this means either $\Gamma_1 = \emptyset$ or $\Gamma_2 = \emptyset$. \square

5. KAZHDAN-LUSZTIG POLYNOMIALS AND KOSZULITY

Now we have enough basic tools in place to be able to prove that the algebras K_Λ are Koszul. The key step is the explicit construction of a linear projective resolution of each cell module.

Combinatorial definition of Kazhdan-Lusztig polynomials. In this subsection we recall a beautiful closed formula for the Kazhdan-Lusztig polynomials associated to Grassmannians discovered by Lascoux and Schützenberger [LS]; see also [Z]. Actually we are going reformulate [LS] in terms of cap diagrams to

match the combinatorial language we are using everywhere else; one advantage of this is that the reformulation also makes sense for unbounded weights.

We begin by introducing some length functions. For a block Λ , let $I(\Lambda)$ denote the (possibly infinite) set of integers indexing vertices of weights in Λ whose labels are *not* \circ or \times . For $\lambda, \mu \in \Lambda$, let $I(\lambda, \mu)$ denote the (necessarily finite) subset of $I(\Lambda)$ indexing the vertices that are labelled differently in λ and μ . For any $i \in I(\Lambda)$, we define

$$\begin{aligned} \ell_i(\lambda, \mu) := & \#\{j \in I(\lambda, \mu) \mid j \leq i \text{ and vertex } j \text{ of } \lambda \text{ is labelled } \vee\} \\ & - \#\{j \in I(\lambda, \mu) \mid j \leq i \text{ and vertex } j \text{ of } \mu \text{ is labelled } \vee\}. \end{aligned} \quad (5.1)$$

So $\ell_i(\lambda, \mu)$ counts how many more \vee 's there are in λ compared to μ on the vertices to the left or equal to the i th vertex. We note that $\lambda \leq \mu$ in the Bruhat ordering if and only if $\ell_i(\lambda, \mu) \geq 0$ for all $i \in I(\Lambda)$. Introduce the *relative length function* on Λ by setting

$$\ell(\lambda, \mu) := \sum_{i \in I(\Lambda)} \ell_i(\lambda, \mu). \quad (5.2)$$

If $\lambda \leq \mu$, this is just the minimum number of transpositions of neighbouring \vee/\wedge pairs needed to get from λ to μ , where “neighbouring” means separated only by \circ 's and \times 's.

Any cap diagram c cuts the upper half space above the number line into various open connected regions. We refer to these as the *chambers* of the cap diagram c . A *labelled cap diagram* C is a cap diagram whose chambers have been labelled by integers in such a way that

- ▶ external (unbounded) chambers are labelled by zero;
- ▶ given two chambers separated by a cap, the label in the inside chamber is greater than or equal to the label in the outside chamber.

If C is a labelled cap diagram we let $|C|$ denote the sum of its labels. In any cap diagram, we refer to a cap in the diagram that does not contain any smaller nested caps as a *small cap*.

Now we are ready to define the (combinatorial) Kazhdan-Lusztig polynomials $p_{\lambda, \mu}(q)$ for each $\lambda, \mu \in \Lambda$. If $\lambda \not\leq \mu$ then we set $p_{\lambda, \mu}(q) := 0$. If $\lambda \leq \mu$, let $D(\lambda, \mu)$ denote the set of all labelled cap diagrams obtained by labelling the chambers of $\bar{\mu}$ in such a way that the label inside every small cap is less than or equal to $\ell_i(\lambda, \mu)$, where i indexes the leftmost vertex of the small cap. Set

$$p_{\lambda, \mu}(q) := q^{\ell(\lambda, \mu)} \sum_{C \in D(\lambda, \mu)} q^{-2|C|}. \quad (5.3)$$

It is not immediately obvious from (5.3) that $p_{\lambda, \mu}(q)$ is actually a polynomial in q , but that is clear from Lemma 5.2 below. We will write $p_{\lambda, \mu}^{(n)}$ for the q^n -coefficient of $p_{\lambda, \mu}(q)$, so

$$p_{\lambda, \mu}(q) = \sum_{n \geq 0} p_{\lambda, \mu}^{(n)} q^n. \quad (5.4)$$

We also define the corresponding matrix

$$P_{\Lambda}(q) := (p_{\lambda, \mu}(q))_{\lambda, \mu \in \Lambda}. \quad (5.5)$$

Here is an example illustrating the computation of $p_{\lambda,\mu}(q)$ in practise:

$$\begin{array}{c}
 \mu = \begin{array}{c} \text{0} \\ \text{0} \\ \text{0/1} \\ \text{0/1} \\ \text{0} \end{array} \\
 \ell_i(\lambda, \mu) = \begin{array}{ccccccccccccccc} \text{0} & \text{0} & \text{1} & \text{1} & \text{1} & \text{1} & \text{2} & \text{2} & \text{2} & \text{2} & \text{2} & \text{1} & \text{1} & \text{0} \end{array} \\
 \lambda = \begin{array}{ccccccccccccccc} \text{v} & \text{v} & \text{v} & \text{v} & \text{v} & \text{v} & \text{v} & \text{v} & \text{v} & \text{v} & \text{v} & \text{v} & \text{v} & \text{v} \end{array} \\
 p_{\lambda,\mu}(q) = q^{16}(1+q^{-2})(1+q^{-2}+q^{-4}).
 \end{array}$$

Remark 5.1. If $|\Lambda| < \infty$, the polynomials $p_{\lambda,\mu}(q)$ are almost exactly the same as the polynomials $Q_w^v(q)$ defined in [LS, §6], which are shown in [LS, Théorème 7.8] to be equal to the (geometric) Kazhdan-Lusztig polynomials associated to Grassmannians in the sense of [KL]. To be precise, for $\lambda \in \Lambda$, let $w(\lambda)$ denote the word in symbols α and β obtained by reading the vertices of λ from left to right and writing α for each \vee and β for each \wedge . Then we have that

$$p_{\lambda,\mu}(q) = q^{\ell(\lambda,\mu)} Q_{w(\mu)}^{w(\lambda)}(q^{-2}).$$

This equality follows by translating the combinatorial description from [LS].

In the next subsection we need instead a recursive description of the polynomials $p_{\lambda,\mu}(q)$ from [LS]. To formulate this, given neighbouring indices $i < j$ from $I(\Lambda)$, we let

$$\Lambda_{i,j}^{\vee\wedge} := \left\{ \nu \in \Lambda \mid \begin{array}{l} \text{the } i\text{th vertex of } \nu \text{ is labelled } \vee \\ \text{the } j\text{th vertex of } \nu \text{ is labelled } \wedge \end{array} \right\}. \quad (5.6)$$

The following lemma repeats [LS, Lemme 6.6] (and its proof).

Lemma 5.2. *The polynomials $p_{\lambda,\mu}(q)$ are determined uniquely by the following properties.*

- (i) *If $\lambda = \mu$ then $p_{\lambda,\mu}(q) = 1$ and if $\lambda \not\leq \mu$ then $p_{\lambda,\mu}(q) = 0$.*
- (ii) *If $\lambda < \mu$, pick neighbouring indices $i < j$ from $I(\Lambda)$ such that $\lambda \in \Lambda_{i,j}^{\vee\wedge}$. Then*

$$p_{\lambda,\mu}(q) = \begin{cases} p_{\lambda',\mu'}(q) + qp_{\lambda'',\mu}(q) & \text{if } \mu \in \Lambda_{i,j}^{\vee\wedge}, \\ qp_{\lambda'',\mu}(q) & \text{otherwise,} \end{cases}$$

where λ' and μ' denote the weights in some “smaller” block obtained from λ and μ by deleting vertices i and j , and λ'' is the weight obtained from λ by transposing the labels on vertices i and j .

Proof. We just check (ii). If $\mu \in \Lambda_{i,j}^{\vee\wedge}$ then $\ell_i(\lambda, \mu) = \ell_i(\lambda', \mu) + 1$ and $\ell(\lambda, \mu) = \ell(\lambda', \mu') + 1$. There is a bijection from $D(\lambda'', \mu) \sqcup D(\lambda', \mu')$ to $D(\lambda, \mu)$ mapping $C \in D(\lambda'', \mu)$ to itself and $C \in D(\lambda', \mu')$ to the labelled cap diagram obtained by adding vertices i and j and a small cap between them labelled by $\ell_i(\lambda, \mu)$. Using these observations and (5.3), we get that $p_{\lambda,\mu}(q) = p_{\lambda',\mu'}(q) + qp_{\lambda'',\mu}(q)$. Instead if $\mu \notin \Lambda_{i,j}^{\vee\wedge}$ then $\ell_i(\lambda, \mu) = \ell_i(\lambda'', \mu) + 1$ and $D(\lambda, \mu) = D(\lambda'', \mu)$. Again we get that $p_{\lambda,\mu}(q) = qp_{\lambda'',\mu}(q)$. \square

Linear projective resolutions of cell modules. Recall the cell modules from (4.2). The following theorem is the central result of the section; the proof here is based on [B, Lemma 4.49].

Theorem 5.3. *For $\lambda \in \Lambda$, there is an exact sequence*

$$\cdots \xrightarrow{d_1} P_1(\lambda) \xrightarrow{d_0} P_0(\lambda) \xrightarrow{\varepsilon} V(\lambda) \longrightarrow 0$$

where $P_0(\lambda) := P(\lambda)$ and $P_n(\lambda) := \bigoplus_{\mu \in \Lambda} p_{\lambda, \mu}^{(n)} P(\mu) \langle n \rangle$ for $n \geq 0$.

Proof. As $P_0(\lambda)$ is the projective cover $P(\lambda)$ of $V(\lambda)$, there is a surjection $\varepsilon : P_0(\lambda) \rightarrow V(\lambda)$. We show by simultaneous induction on $\text{def}(\lambda)$ and $n = 0, 1, \dots$ that there exist maps $d_n : P_{n+1}(\lambda) \rightarrow P_n(\lambda)$ such that $\text{im } d_n = \ker d_{n-1}$, interpreting d_{-1} as the map ε . If $\text{def}(\lambda) = 0$ then λ is maximal in the Bruhat ordering, so $P(\lambda) = V(\lambda)$ by [BS, Theorem 5.1] and $P_1(\lambda) = P_2(\lambda) = \cdots = 0$. Hence all the maps d_0, d_1, \dots are necessarily zero and ε is an isomorphism. This verifies the assertion for $\text{def}(\lambda) = 0$.

Now we assume that $n \geq 0$, $\text{def}(\lambda) > 0$ and that we have already constructed the maps $d_m : P_{m+1}(\lambda) \rightarrow P_m(\lambda)$ for all $0 \leq m < n$. Choose neighbouring indices $i < j$ from $I(\Lambda)$ such that $\lambda \in \Lambda_{i,j}^{\vee \wedge}$. Recalling (5.6), let Γ denote the ‘‘smaller’’ block consisting of all weights obtained by removing vertices i and j from the weights in $\Lambda_{i,j}^{\vee \wedge}$, and let $\Lambda_{i,j}^{\vee \wedge} \rightarrow \Gamma$, $\nu \mapsto \nu'$ be the obvious bijection defined by letting ν' denote the weight obtained from ν by deleting vertices i and j . Let t be the proper $\Lambda\Gamma$ -matching with a cap joining vertices i and j on the bottom number line and vertical line segments joining all other corresponding pairs of vertices in the bottom and top number lines (skipping vertices labelled \circ or \times). The definition of t means that $\bar{\mu}$ is the upper reduction of $t\bar{\mu}'$ for every $\mu \in \Lambda_{i,j}^{\vee \wedge}$, hence

$$G_{\Lambda\Gamma}^t P(\mu') \cong P(\mu) \tag{5.7}$$

by Theorem 4.2. Also by Theorem 4.5(i), there is a short exact sequence

$$0 \longrightarrow V(\lambda'') \xrightarrow{f} G_{\Lambda\Gamma}^t V(\lambda') \longrightarrow V(\lambda) \langle -1 \rangle \longrightarrow 0. \tag{5.8}$$

The idea now is to apply the induction hypothesis to the left and middle term of this sequence and then deduce the result for the right hand side by taking the cone of f .

By the induction hypothesis, there are exact sequences

$$\begin{aligned} P_n(\lambda'') &\rightarrow \cdots \rightarrow P_0(\lambda'') \rightarrow V(\lambda'') \rightarrow 0, \\ P_{n+1}(\lambda') &\rightarrow P_n(\lambda') \rightarrow \cdots \rightarrow P_0(\lambda') \rightarrow V(\lambda') \rightarrow 0 \end{aligned}$$

with $P_n(\lambda'') = \bigoplus_{\mu \in \Lambda} p_{\lambda'', \mu}^{(n)} P(\mu) \langle n \rangle$ and $P_{n+1}(\lambda') = \bigoplus_{\mu \in \Lambda_{i,j}^{\vee \wedge}} p_{\lambda', \mu'}^{(n+1)} P(\mu') \langle n+1 \rangle$. Applying the exact functor $G_{\Lambda\Gamma}^t$ to the second of these and then using [W, 2.2.6] to lift the map f from (5.8) to a chain map, we obtain a commuting diagram

$$\begin{array}{ccccccc} P_n(\lambda'') & \rightarrow & \cdots & \rightarrow & P_0(\lambda'') & \rightarrow & V(\lambda'') \rightarrow 0 \\ & & & & \downarrow & & \downarrow f \\ G_{\Lambda\Gamma}^t P_{n+1}(\lambda') & \rightarrow & G_{\Lambda\Gamma}^t P_n(\lambda') & \rightarrow & \cdots & \rightarrow & G_{\Lambda\Gamma}^t P_0(\lambda') \rightarrow G_{\Lambda\Gamma}^t V(\lambda') \rightarrow 0 \end{array}$$

with exact rows. The total complex of this double complex is exact by [W, 2.7.3], so gives an exact sequence

$$P_n(\lambda'') \oplus G_{\Lambda\Gamma}^t P_{n+1}(\lambda') \rightarrow \cdots \rightarrow V(\lambda'') \oplus G_{\Lambda\Gamma}^t P_0(\lambda') \rightarrow G_{\Lambda\Gamma}^t V(\lambda') \rightarrow 0.$$

To this sequence, there is an obvious injective chain map from the exact sequence $0 \rightarrow \cdots \rightarrow 0 \rightarrow V(\lambda'') \rightarrow V(\lambda'') \rightarrow 0$. Taking the quotient using (5.8) and [W, Exercise 1.3.1], we obtain another exact sequence

$$P_n(\lambda'') \oplus G_{\Lambda\Gamma}^t P_{n+1}(\lambda') \rightarrow \cdots \rightarrow G_{\Lambda\Gamma}^t P_0(\lambda') \rightarrow V(\lambda)\langle -1 \rangle \rightarrow 0.$$

Recalling Lemma 5.2 and (5.7), we have that

$$G_{\Lambda\Gamma}^t P_0(\lambda') = G_{\Lambda\Gamma}^t P(\lambda') \cong P(\lambda)\langle -1 \rangle = P_0(\lambda)\langle -1 \rangle$$

and

$$\begin{aligned} P_n(\lambda'') \oplus G_{\Lambda\Gamma}^t P_{n+1}(\lambda') &\cong \bigoplus_{\mu \in \Lambda} p_{\lambda'', \mu}^{(n)} P(\mu)\langle n \rangle \oplus \bigoplus_{\mu \in \Lambda_{i,j}^{\vee \wedge}} p_{\lambda'', \mu'}^{(n+1)} P(\mu)\langle n \rangle \\ &\cong \bigoplus_{\mu \in \Lambda} p_{\lambda, \mu}^{(n+1)} P(\mu)\langle n \rangle = P_{n+1}(\lambda)\langle -1 \rangle. \end{aligned}$$

So, shifting degrees by one, our exact sequence can be rewritten as an exact sequence

$$P_{n+1}(\lambda) \xrightarrow{d_n} \cdots \xrightarrow{d_0} P_0(\lambda) \xrightarrow{\varepsilon} V(\lambda) \longrightarrow 0.$$

This constructs a map d_n such that $\text{im } d_n = \ker d_{n-1}$, where for $n > 0$ the map d_{n-1} is as constructed in the previous iteration of the induction. \square

Corollary 5.4. *The matrix $P_{\Lambda}(-q)$ is the inverse of the q -decomposition matrix $D_{\Lambda}(q)$ from [BS, (5.13)].*

Proof. Recalling [BS, (5.14)] and the Cartan matrix $C_{\Lambda}(q) = (c_{\lambda, \mu}(q))_{\lambda, \mu \in \Lambda}$ from [BS, (5.6)], we have by Theorem 5.3 that

$$\begin{aligned} d_{\lambda, \mu}(q) &= \sum_{j \geq 0} q^j \dim \text{Hom}_{K_{\Lambda}}(P(\lambda), V(\mu))_j \\ &= \sum_{i, j \geq 0} (-1)^i q^j \dim \text{Hom}_{K_{\Lambda}}(P(\lambda), P_i(\mu))_j \\ &= \sum_{\nu \in \Lambda} \sum_{i, j \geq 0} (-1)^i q^j p_{\mu, \nu}^{(i)} \dim \text{Hom}_{K_{\Lambda}}(P(\lambda), P(\nu)\langle i \rangle)_j \\ &= \sum_{\nu \in \Lambda} \left(\sum_{i \geq 0} (-q)^i p_{\mu, \nu}^{(i)} \right) \left(\sum_{j \geq 0} q^j \dim \text{Hom}_{K_{\Lambda}}(P(\lambda), P(\nu))_j \right) \\ &= \sum_{\nu \in \Lambda} p_{\mu, \nu}(-q) c_{\lambda, \nu}(q). \end{aligned}$$

Using also the familiar factorisation [BS, (5.17)], this shows that

$$D_{\Lambda}(q) = C_{\Lambda}(q) P_{\Lambda}(-q)^T = D_{\Lambda}(q) D_{\Lambda}(q)^T P_{\Lambda}(-q)^T.$$

Now multiply on the left by the inverse matrix $D_{\Lambda}(q)^{-1}$ (which exists in all cases as $D_{\Lambda}(q)$ is a unitriangular matrix) and transpose. \square

The next corollary identifies the polynomials $p_{\lambda,\mu}(q)$ with the (representation theoretic) Kazhdan-Lusztig polynomials associated to the category $\text{Mod}_{lf}(K_\Lambda)$ in the sense of Vogan [V].

Corollary 5.5. *For $\lambda, \mu \in \Lambda$, we have that*

$$p_{\lambda,\mu}(q) = \sum_{i \geq 0} q^i \dim \text{Ext}_{K_\Lambda}^i(V(\lambda), L(\mu)).$$

Moreover, $\text{Ext}_{K_\Lambda}^i(V(\lambda), L(\mu))_{-j} = 0$ unless $i = j \equiv \ell(\lambda, \mu) \pmod{2}$.

Proof. Apply the functor $\text{Hom}_{K_\Lambda}(\cdot, L(\mu))$ to the projective resolution of $V(\lambda)$ constructed in Theorem 5.3 to obtain a cochain complex $0 \rightarrow C^0 \rightarrow C^1 \rightarrow \dots$ with

$$C^i = \bigoplus_{j \in \mathbb{Z}} C^{i,j} = \bigoplus_{j \in \mathbb{Z}} \text{Hom}_{K_\Lambda}(P_i(\lambda), L(\mu))_{-j},$$

the cohomology of which computes $\text{Ext}_{K_\Lambda}^i(V(\lambda), L(\mu))$. We get from the definition of $P_i(\lambda)$ that $\dim C^{i,j} = \delta_{i,j} p_{\lambda,\mu}^{(i)}$. In view of the definition (5.3), this means that $C^{i,j} = 0$ unless $i = j \equiv \ell(\lambda, \mu) \pmod{2}$. In particular, this shows that all the differentials in the cochain complex are zero, so we actually have that $C^{i,j} = \text{Ext}_{K_\Lambda}^i(V(\lambda), L(\mu))_{-j}$. The corollary follows. \square

Koszulity in the finite dimensional case. Recall from [BGS, Definition 1.1.2] that a positively graded associative unital algebra $K = \bigoplus_{n \geq 0} K_n$ is *Koszul* if

- ▶ K_0 is a semisimple algebra;
- ▶ the module $K/K_{>0}$ has a linear projective resolution, i.e. there is an exact sequence $\dots \rightarrow P_2 \rightarrow P_1 \rightarrow P_0 \rightarrow K/K_{>0} \rightarrow 0$ in the category of graded K -modules such that each P_n is projective and generated in degree n .

Theorem 5.6. *If $|\Lambda| < \infty$ then K_Λ is Koszul.*

Proof. Under the assumption that $|\Lambda| < \infty$, K_Λ is a graded quasi-hereditary algebra by [BS, Corollary 5.4]. Moreover by [BS, Theorem 5.3] its left standard modules in the usual sense of quasi-hereditary algebras are the cell modules $V(\lambda)$. Hence Theorem 5.3 establishes that its left standard modules have linear projective resolutions. Twisting with the anti-automorphism $*$ from [BS, (4.14)] we also get that its right standard modules have linear projective resolutions. Therefore K_Λ is Koszul by [ADL, Theorem 1]. (Alternatively, this can be deduced from [CPS, Theorem (3.9)] and Corollary 5.5.) \square

Corollary 5.7. *If $|\Lambda| < \infty$ then K_Λ is a quadratic algebra.*

Proof. This is [BGS, Corollary 2.3.3]. \square

For the next corollary, we recall the definition of the Koszul complex following [BGS, 2.6]. Still assuming $|\Lambda| < \infty$, let k_Λ denote the semisimple algebra $(K_\Lambda)_0$ and write \otimes for \otimes_{k_Λ} . By Corollary 5.7, we can identify K_Λ with $T(V_\Lambda)/(R_\Lambda)$ where $T(V_\Lambda)$ is the tensor algebra of the k_Λ -module $V_\Lambda := (K_\Lambda)_1$ and R_Λ is the

subspace of $V_\Lambda \otimes V_\Lambda$ consisting of the elements whose canonical image in $(K_\Lambda)_2$ is zero. Let $P_0 := K_\Lambda$, $P_1 := K_\Lambda \otimes V_\Lambda$ and

$$P_n := K_\Lambda \otimes \bigcap_{i=0}^{n-2} \left(V_\Lambda^{\otimes i} \otimes R_\Lambda \otimes V_\Lambda^{\otimes (n-2-i)} \right) \quad (5.9)$$

for $n \geq 2$, all viewed as K_Λ -modules via the left regular action on the first tensor factor. The *Koszul complex* for K_Λ is

$$\cdots \xrightarrow{d_2} P_2 \xrightarrow{d_1} P_1 \xrightarrow{d_0} P_0 \xrightarrow{\varepsilon} K_\Lambda / (K_\Lambda)_{>0} \longrightarrow 0 \quad (5.10)$$

where the differential d_n is the map $a \otimes v_0 \otimes \cdots \otimes v_n \mapsto av_0 \otimes \cdots \otimes v_n$, and ε is the natural quotient map. The following corollary implies that the Koszul complex is a canonical linear projective resolution of $K_\Lambda / (K_\Lambda)_{>0}$.

Corollary 5.8. *If $|\Lambda| < \infty$ then the Koszul complex for K_Λ is exact.*

Proof. This is [BGS, Theorem 2.6.1]. \square

To formulate the final corollary, recall the matrix $P_\Lambda(q)$ from (5.5) and the Cartan matrix $C_\Lambda(q)$ from [BS, (5.6)]. Continuing to assume that $|\Lambda| < \infty$, define the *Poincaré matrix*

$$E_\Lambda(q) := (e_{\lambda,\mu}(q))_{\lambda,\mu \in \Lambda} \quad (5.11)$$

where $e_{\lambda,\mu}(q) := \sum_{i \geq 0} q^i \dim \text{Ext}_{K_\Lambda}^i(L(\lambda), L(\mu))$. Because K_Λ has finite global dimension in our current situation each $e_{\lambda,\mu}(q)$ is a polynomial.

Corollary 5.9. *If $|\Lambda| < \infty$ then $E_\Lambda(q) = C_\Lambda(-q)^{-1} = P_\Lambda(q)^T P_\Lambda(q)$.*

Proof. The first equality is [BGS, Theorem 2.11.1]. The second equality follows by inverting the formula $C_\Lambda(-q) = D_\Lambda(-q)D_\Lambda(-q)^T$ from [BS, (5.17)] and using Corollary 5.4. \square

Koszulity in the general case. Recall a *locally unital algebra* K is an associative algebra with a system $\{e_i \mid i \in I\}$ of mutually orthogonal idempotents such that $K = \bigoplus_{i,j \in I} e_i K e_j$. There is a natural notion of a *locally unital Koszul algebra*: a locally unital positively graded algebra $K = \bigoplus_{n \geq 0} K_n$ such that

- ▶ K_0 is a (possibly infinite) direct sum of matrix algebras;
- ▶ the module $K/K_{>0}$ has a linear projective resolution.

Assume for the remainder of the subsection that Λ is block with $|\Lambda| = \infty$. The algebra K_Λ is not unital but it is locally unital; see [BS, (4.13)]. We wish to prove that it is Koszul in the new sense. (We remark that a detailed treatment of quadratic and Koszul duality for non-unital algebras, based on the approach of [MVS], can be found for example in [MOS].)

Recall the notation \prec from [BS, §4]. If $\Gamma \prec \Lambda$ then Γ is a finite block that is canonically identified with a finite subset of Λ ; see [BS, (4.9)]. Moreover the algebra K_Γ is canonically identified with a subalgebra of K_Λ ; see [BS, (4.12)]. Any finite subset of Λ is contained in some $\Gamma \prec \Lambda$. It follows that any finite dimensional subspace of K_Λ is contained in K_Γ for some $\Gamma \prec \Lambda$. Since each K_Γ is quadratic by Corollary 5.7 we deduce:

Lemma 5.10. K_Λ is quadratic.

Let $k_\Lambda := (K_\Lambda)_0$, which is an infinite direct sum of copies of the ground field by [BS, (5.2)]. Let $V_\Lambda := (K_\Lambda)_1$ and $R_\Lambda \subseteq V_\Lambda \otimes V_\Lambda$ denote the elements whose canonical image in $(K_\Lambda)_2$ is zero. Lemma 5.10 means we can identify $K_\Lambda = T(V_\Lambda)/(R_\Lambda)$. Now construct the Koszul complex

$$\cdots \xrightarrow{d_2} P_2 \xrightarrow{d_1} P_1 \xrightarrow{d_0} P_0 \xrightarrow{\varepsilon} K_\Lambda/(K_\Lambda)_{>0} \longrightarrow 0 \quad (5.12)$$

in the infinite dimensional case in exactly the same way as (5.10). Note for $\Gamma \prec \Lambda$ that V_Γ is a subspace of V_Λ and R_Γ is a subspace of R_Λ .

Lemma 5.11. Given $n \geq 0$ and $\lambda, \mu \in \Lambda$, there exists $\Gamma \prec \Lambda$ such that $\lambda, \mu \in \Gamma$ and $e_\mu V_\Lambda^{\otimes n} e_\lambda = e_\mu V_\Gamma^{\otimes n} e_\lambda$. Hence

$$e_\mu \prod_{i=0}^{n-2} \left(V_\Lambda^{\otimes i} \otimes R_\Lambda \otimes V_\Lambda^{\otimes (n-2-i)} \right) e_\lambda = e_\mu \prod_{i=0}^{n-2} \left(V_\Gamma^{\otimes i} \otimes R_\Gamma \otimes V_\Gamma^{\otimes (n-2-i)} \right) e_\lambda.$$

Proof. Note $e_\mu V_\Lambda^{\otimes n} e_\lambda$ is spanned by vectors of the form

$$(\underline{\lambda}_0 \nu_1 \bar{\lambda}_1) \otimes (\underline{\lambda}_1 \nu_2 \bar{\lambda}_2) \otimes \cdots \otimes (\underline{\lambda}_{n-1} \nu_n \bar{\lambda}_n)$$

for weights $\lambda_i, \nu_j \in \Lambda$ such that $\lambda_0 = \mu, \lambda_n = \lambda$ and each $\underline{\lambda}_{i-1} \nu_i \bar{\lambda}_i$ is an oriented circle diagram of degree one. By [BS, Lemma 2.4] there are only finitely many such weights. Hence we can find $\Gamma \prec \Lambda$ such that all possible $\lambda_i, \nu_j \in \Lambda$ actually belong to Γ . Then it is clear that $e_\mu V_\Lambda^{\otimes n} e_\lambda = e_\mu V_\Gamma^{\otimes n} e_\lambda$. The second statement follows by similar considerations. \square

Theorem 5.12. The Koszul complex is exact.

Proof. The image of d_0 is the kernel of ε and of course ε is surjective. So it suffices to show that the complex of vector spaces

$$0 \longrightarrow (e_\mu P_m e_\lambda)_m \xrightarrow{d_{m-1}} \cdots \xrightarrow{d_1} (e_\mu P_1 e_\lambda)_m \xrightarrow{d_0} (e_\mu P_0 e_\lambda)_m$$

is exact for each $\lambda, \mu \in \Lambda$ and $m \geq 0$. The elements of all of the vector spaces appearing in this complex are linear combinations of vectors of the form

$$(\underline{\mu} \nu_0 \bar{\lambda}_0) \otimes (\underline{\lambda}_0 \nu_1 \bar{\lambda}_1) \otimes \cdots \otimes (\underline{\lambda}_{n-1} \nu_n \bar{\lambda}_n)$$

for $0 \leq n \leq m$ and $\lambda_i, \nu_j \in \Lambda$ with $\lambda_n = \lambda$ such that $\underline{\mu} \nu_0 \bar{\lambda}_0$ is an oriented circle diagram of degree $(m-n)$ and each $\underline{\lambda}_{i-1} \nu_i \bar{\lambda}_i$ is an oriented circle diagram of degree one. By [BS, Lemma 2.4] there are only finitely many such weights. Hence we can find $\Gamma \prec \Lambda$ such that all possible λ_i, ν_j belong to Γ . Just like in the proof of Lemma 5.11, we deduce that $(e_\mu P_n e_\lambda)_m = (e_\mu Q_n e_\lambda)_m$ where Q_n denotes the n th term in the Koszul complex for K_Γ . Now we are done because the Koszul complex for K_Γ is already known to be exact by Corollary 5.8. \square

Corollary 5.13. K_Λ is Koszul.

Proof. The Koszul complex is a linear projective resolution of $K_\Lambda/(K_\Lambda)_{>0}$. \square

Corollary 5.14. Given $\lambda, \mu \in \Lambda$ and $n \geq 0$, there exists $\Gamma \prec \Lambda$ such that $\lambda, \mu \in \Gamma$ and $\text{Ext}_{K_\Lambda}^n(L(\lambda), L(\mu)) \cong \text{Ext}_{K_\Gamma}^n(L(\lambda), L(\mu))$.

Proof. Multiplying the Koszul complex (5.12) on the right by e_λ gives a projective resolution of $L(\lambda)$. Then apply the functor $\text{Hom}_{K_\Lambda}(?, L(\mu))$ and use adjointness of tensor and hom to deduce that

$$\text{Ext}_{K_\Lambda}^n(L(\lambda), L(\mu)) \cong e_\mu \bigcap_{i=0}^{n-2} \left(V_\Lambda^{\otimes i} \otimes R_\Lambda \otimes V_\Lambda^{\otimes (n-2-i)} \right) e_\lambda,$$

interpreting the right hand side as $e_\mu V_\Lambda e_\lambda$ in case $n = 1$ and as $e_\mu k_\Lambda e_\lambda$ in case $n = 0$. Now apply Lemma 5.11. \square

The previous corollary implies in particular that each $\text{Ext}_{K_\Lambda}^n(L(\lambda), L(\mu))$ is finite dimensional. So it still makes sense to define the Poincaré matrix $E_\Lambda(q)$ exactly as in (5.11), though its entries may now be power series rather than polynomials.

Corollary 5.15. $E_\Lambda(q) = C_\Lambda(-q)^{-1} = P_\Lambda(q)^T P_\Lambda(q)$.

Proof. In view of the factorisation [BS, (5.17)] and Corollary 5.4, we just need to show that

$$\dim \text{Ext}_{K_\Lambda}^n(L(\lambda), L(\mu)) = \sum_{m=0}^n \sum_{\nu \in \Lambda} p_{\nu, \lambda}^{(m)} p_{\nu, \mu}^{(n-m)}$$

for each fixed $n \geq 0$. By Corollary 5.14 we can pick $\Gamma \prec \Lambda$ (depending on n) such that $\text{Ext}_{K_\Lambda}^n(L(\lambda), L(\mu)) \cong \text{Ext}_{K_\Gamma}^n(L(\lambda), L(\mu))$. Applying Corollary 5.9 to Γ , it remains to show that

$$\sum_{m=0}^n \sum_{\nu \in \Lambda} p_{\nu, \lambda}^{(m)} p_{\nu, \mu}^{(n-m)} = \sum_{m=0}^n \sum_{\nu \in \Gamma} p_{\nu, \lambda}^{(m)} p_{\nu, \mu}^{(n-m)}. \quad (5.13)$$

By the proof of Corollary 5.14, $\text{Ext}_{K_\Gamma}^n(L(\lambda), L(\mu)) \cong \text{Ext}_{K_\Upsilon}^n(L(\lambda), L(\mu))$ for any $\Gamma \prec \Upsilon \prec \Lambda$. Applying Corollary 5.9 to Υ , we deduce that (5.13) is definitely true if Λ is replaced by any such a block Υ . Hence the equality must also be true for Λ itself. \square

6. THE DOUBLE CENTRALISER PROPERTY

In this section, we are at last able to explain the full connection between the generalised Khovanov algebra H_Λ and the algebra K_Λ . If Λ is of infinite defect then $H_\Lambda = \{0\}$, in which case there is of course no connection at all. In all other cases, we are going to prove a double centralizer property which implies that K_Λ is a quasi-hereditary cover of H_Λ in the sense of [R, Definition 4.34].

Prinjective modules. To start with, let Λ be any block. We call a K_Λ -module a *prinjective module* if it is both projective and injective in the category of locally finite dimensional graded K_Λ -modules. The next theorem is rather analogous to a theorem of Irving [I] in the context of parabolic category \mathcal{O} . It shows that the prinjective indecomposable modules are parametrised by exactly the set Λ° of weights of maximal defect that appears in the definition (3.17) of H_Λ (no coincidence!).

Theorem 6.1. *For $\lambda \in \Lambda$, the following conditions are equivalent:*

- (i) λ is of maximal defect, i.e. λ belongs to Λ° ;
- (ii) $P(\lambda)^\otimes \cong P(\lambda)\langle -2 \operatorname{def}(\lambda) \rangle$;
- (iii) $P(\lambda)$ is a prinjective module;
- (iv) $L(\lambda)$ is isomorphic to a submodule of $V(\mu)\langle j \rangle$ for some $\mu \in \Lambda$, $j \in \mathbb{Z}$.

Proof. (i) \Rightarrow (ii). Assume that $\lambda \in \Lambda^\circ$. There exists a block $\Gamma = \{\gamma\}$ of defect 0 and a proper $\Lambda\Gamma$ -matching t such that $\bar{\lambda}$ is the upper reduction of $\underline{\gamma}t$. This matching t has $\operatorname{caps}(t) = \operatorname{def}(\lambda)$ and $\operatorname{cups}(t) = 0$. By Theorem 4.2,

$$P(\lambda) \cong (G_{\Lambda\Gamma}^t P(\gamma))\langle \operatorname{def}(\lambda) \rangle.$$

As $P(\gamma)$ is irreducible, we have that $P(\gamma)^\otimes \cong P(\gamma)$. Hence by Theorem 4.10, we deduce that $P(\lambda)^\otimes \cong P(\lambda)\langle -2 \operatorname{def}(\lambda) \rangle$.

(ii) \Rightarrow (iii). This follows by duality because $P(\lambda)$ is projective in the category of locally finite dimensional graded K_Λ -modules.

(iii) \Rightarrow (iv). As $L(\lambda)$ is the irreducible head of $P(\lambda)$, we deduce that $L(\lambda)$ is the irreducible socle of $P(\lambda)^\otimes$. Assuming (iii), $P(\lambda)^\otimes$ is a projective module. By [BS, Theorem 5.1], projective modules have a filtration by cell modules. Hence $P(\lambda)^\otimes$ has a submodule isomorphic to $V(\mu)\langle j \rangle$ for some $\mu \in \Lambda$ and $j \in \mathbb{Z}$, such that $L(\lambda)$ is a submodule of this $V(\mu)\langle j \rangle$.

(iv) \Rightarrow (i). Take $\mu \in \Lambda$ and suppose that w is a vector spanning an irreducible K_Λ -submodule of $V(\mu)$ isomorphic to $L(\lambda)\langle -j \rangle$ for some $\lambda \in \Lambda$ and $j \in \mathbb{Z}$. Since e_λ acts as 1 on $L(\lambda)$ and as zero on all the basis vectors $(\underline{\nu}\mu|)$ of $V(\mu)$ for $\lambda \neq \nu$, we may assume actually that $\underline{\lambda}\mu$ is an oriented cup diagram and $w = (\underline{\lambda}\mu|)$. We need to show that λ is of maximal defect.

Assume for a contradiction that λ is not of maximal defect. Then we can find a pair of rays in the diagram $\underline{\lambda}\mu$ that are oppositely oriented and neighbouring (in the sense that there are only vertices labelled \circ or \times at the ends of cups in between). Define ν so that $\underline{\nu}$ is obtained from $\underline{\lambda}$ by replacing these two rays by a single cup. We then have that $\underline{\nu}\lambda$ and $\underline{\nu}\mu$ are oriented cup diagrams, and $\nu \neq \lambda$. By [BS, Theorem 4.4(iii)] and (4.2), we see that $(\underline{\nu}\lambda\bar{\lambda})(\underline{\lambda}\mu|) = (\underline{\nu}\mu|)$. This contradicts the assumption that $w = (\underline{\lambda}\mu|)$ spans a K_Λ -submodule of $V(\mu)$. \square

“Struktursatz”. From now on we assume that $\operatorname{def}(\Lambda) < \infty$. The following theorem is key to proving the double centraliser property.

Theorem 6.2. *For each $\lambda \in \Lambda$, there is an exact sequence*

$$0 \rightarrow P(\lambda) \rightarrow P^0 \rightarrow P^1$$

where P^0 and P^1 are finite direct sums of prinjective indecomposable modules.

Proof. Assume to start with that λ is maximal in Λ with respect to the Bruhat order. Then $P(\lambda) = V(\lambda)$ by [BS, Theorem 5.1]. Let μ be the weight obtained from λ by swapping $\operatorname{def}(\Lambda) \wedge$'s with $\operatorname{def}(\Lambda) \vee$'s. This ensures that $\mu \in \Lambda^\circ$ and $\lambda\bar{\mu}$ is an oriented cap diagram of degree $\operatorname{def}(\Lambda)$. By [BS, Theorem 5.1] again we deduce that $V(\lambda)$ embeds into $P^0 := P(\mu)\langle -\operatorname{def}(\Lambda) \rangle$ and the quotient $P^0/V(\lambda)$ has a filtration by cell modules. By Theorem 6.1 P^0 is a prinjective indecomposable module, the socle of $P^0/V(\lambda)$ is a finite direct sum of $L(\nu)\langle j \rangle$'s for $\nu \in \Lambda^\circ$, and the injective hull of each such $L(\nu)\langle j \rangle$ is the prinjective indecomposable module $P(\nu)\langle j - 2 \operatorname{def}(\nu) \rangle$. Hence the injective hull P^1 of $P^0/V(\lambda)$ is

a finite direct sum of prinjective indecomposable modules. This constructs the desired exact sequence $0 \rightarrow P(\lambda) \rightarrow P^0 \rightarrow P^1$.

Now for the general case, let γ be the weight obtained from λ by removing the vertices at the ends of all caps in the cap diagram $\bar{\lambda}$. Then the diagram $\bar{\gamma}$ has no caps, hence γ is maximal in its block Γ . Let t be the proper $\Lambda\Gamma$ -matching such that $\bar{\lambda}$ is the upper reduction of $t\bar{\gamma}$. The previous paragraph applied to γ implies there is an exact sequence $0 \rightarrow P(\gamma)\langle\text{caps}(t)\rangle \rightarrow Q^0 \rightarrow Q^1$ with Q^0 and Q^1 being finite direct sums of (possible several copies of) prinjective indecomposable modules. Now apply the functor $G_{\Lambda\Gamma}^t$, noting $G_{\Lambda\Gamma}^t(P(\gamma)\langle\text{caps}(t)\rangle) \cong P(\lambda)$ by Theorem 4.2, to obtain an exact sequence $0 \rightarrow P(\lambda) \rightarrow P^0 \rightarrow P^1$ where $P^i := G_{\Lambda\Gamma}^t Q^i$. Since F sends finitely generated prinjectives to finitely generated prinjectives by Corollary 4.4 and Theorem 4.10, each P^i is a finite direct sum of prinjective indecomposable modules, as required. \square

The following corollary is analogous to Soergel's Struktursatz from [S] for regular blocks of category \mathcal{O} (hence the title of this subsection).

Corollary 6.3. *The truncation functor $e : \text{Mod}_f(K_\Lambda) \rightarrow \text{Mod}_f(H_\Lambda)$ from (3.19) is fully faithful on projectives.*

Proof. This follows by the theorem and [KSX, Theorem 2.10]; see also [S3, Corollary 1.7] for a self-contained argument. \square

Corollary 6.4. *The truncation functor $e : \text{Mod}_f(K_\Lambda) \rightarrow \text{Mod}_f(H_\Lambda)$ from (3.19) defines a graded algebra isomorphism*

$$K_\Lambda \cong \bigoplus_{\lambda, \mu \in \Lambda} \text{Hom}_{H_\Lambda}(eP(\lambda), eP(\mu)),$$

where the right hand side becomes an algebra with multiplication defined by the rule $fg := g \circ f$ for $f : eP(\lambda) \rightarrow eP(\mu)$ and $g : eP(\mu) \rightarrow eP(\nu)$.

Proof. By the previous corollary, there is a vector space isomorphism

$$e_\lambda K_\Lambda e_\mu \xrightarrow{\sim} \text{Hom}_{H_\Lambda}(eP(\lambda), eP(\mu))$$

sending $x \in e_\lambda K_\Lambda e_\mu$ to the map $eP(\lambda) \rightarrow eP(\mu)$ obtained by applying the functor e to the homomorphism $P(\lambda) \rightarrow P(\mu)$ defined by right multiplication by x . Now take the direct sum of these maps over all $\lambda, \mu \in \Lambda$. \square

Remark 6.5. This double centraliser property is most interesting in the case that $|\Lambda| < \infty$. Then $e = \sum_{\lambda \in \Lambda^\circ} e_\lambda$ is an idempotent in K_Λ , the generalised Khovanov algebra H_Λ is equal to $eK_\Lambda e \cong \text{End}_{K_\Lambda}(K_\Lambda e)^{\text{op}}$, the functor e is the obvious truncation functor defined by multiplication by e , and the double centralizer property shows simply that

$$K_\Lambda \cong \text{End}_{H_\Lambda}(eK_\Lambda)^{\text{op}}.$$

If $|\Lambda| = \infty$ (but still $\text{def}(\Lambda) < \infty$) it often happens that $H_\Lambda = K_\Lambda$, in which case the double centraliser property is rather vacuous; see [BS, (6.11)].

Rigidity of cell modules. Continue to assume that $\text{def}(\Lambda) < \infty$ and fix $\lambda \in \Lambda$. We know already from Theorem 6.1 that all constituents of the socle of

the cell module $V(\lambda)$ are parametrized by weights from the set Λ° . We want to make this more precise by showing that $V(\lambda)$ actually has irreducible socle.

Let λ° be the unique weight $\mu \in \Lambda^\circ$ such that $\underline{\mu}\lambda$ is oriented and $\deg(\underline{\mu}\lambda)$ is maximal. To compute λ° in practise, start from the diagram λ . Add clockwise cups to the diagram by repeatedly connecting $\wedge\vee$ pairs of vertices that are neighbours in the sense that there are no vertices in between not yet connected to cups. When no more such pairs are left, add nested anti-clockwise cups connecting as many as possible of the remaining vertices together in $\vee\wedge$ pairs. Finally add rays (which will be oriented so either all are \vee or all are \wedge) to any vertices left at the end. Then λ° is the weight whose associated cup diagram $\underline{\lambda}^\circ$ is the cup diagram just constructed. For example, if $\lambda = \vee\vee\vee\wedge\wedge\vee\wedge\wedge\vee\vee\wedge$ then $\lambda^\circ = \vee\vee\vee\wedge\vee\wedge\vee\vee\wedge\wedge\wedge$:

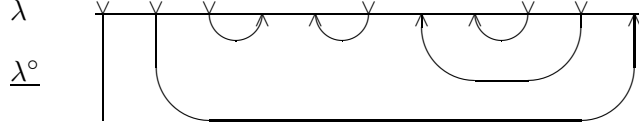

Theorem 6.6. *For any $\lambda \in \Lambda$, we have that $\text{soc } V(\lambda) \cong L(\lambda^\circ)\langle \deg(\underline{\lambda}^\circ\lambda) \rangle$.*

Proof. By the definition of λ° and [BS, Theorem 5.2], $L(\lambda^\circ)\langle \deg(\underline{\lambda}^\circ\lambda) \rangle$ belongs to $\text{soc } V(\lambda)$. Therefore it suffices to show that the socle of $V(\lambda)$ is irreducible.

We begin with two easy situations. First suppose that λ is minimal in the Bruhat order on Λ . Then $V(\lambda) = L(\lambda)$ and the conclusion is trivial. Instead suppose that $\deg(\underline{\lambda}^\circ\lambda) = \text{def}(\Lambda)$. Then $V(\lambda)\langle \text{def}(\Lambda) \rangle$ is a submodule of $P(\lambda^\circ)$ thanks to [BS, Theorem 5.1]. As $P(\lambda^\circ)$ has irreducible socle by Theorem 6.1(ii), we deduce that $V(\lambda)$ has irreducible socle too.

Next suppose that Λ does not have a smallest element in the Bruhat order. This implies that $|\Lambda| = \infty$ and moreover every weight $\lambda \in \Lambda$ has the property that $\deg(\underline{\lambda}^\circ\lambda) = \text{def}(\Lambda)$. So we are done thanks to the second easy situation just discussed. Hence we may assume that Λ has a smallest element in the Bruhat order, and proceed by ascending induction on the Bruhat ordering. The base case of the induction is the first easy situation just mentioned. For the induction step, take $\lambda \in \Lambda$ that is not minimal, and let μ be the weight obtained from λ by interchanging some $\wedge\vee$ pair of vertices that are neighbours in the usual sense. Denote the indices of this pair of vertices by $i < j$. We know by induction that $\text{soc } V(\mu) \cong L(\nu)\langle j \rangle$ for some $\nu \in \Lambda^\circ$ and $j \geq 0$. Moreover as $\nu \in \Lambda^\circ$ the injective hull of $L(\nu)\langle j \rangle$ is isomorphic to $P(\nu)\langle j - 2 \text{def}(\Lambda) \rangle$ thanks to Theorem 6.1(ii). Hence there is an embedding $V(\mu) \hookrightarrow P(\nu)\langle j - 2 \text{def}(\Lambda) \rangle$.

Let t be the $\Lambda\Lambda$ -matching with a cap joining vertices i and j on the bottom number line, a cup joining vertices i and j on the top number line, and straight line segments everywhere else. Let $G_{\Lambda\Lambda}^t$ be the corresponding projective functor. By Theorem 4.5, there is an embedding $V(\lambda) \hookrightarrow G_{\Lambda\Lambda}^t V(\mu)$. Applying $G_{\Lambda\Lambda}^t$ to our earlier embedding, we deduce that $V(\lambda) \hookrightarrow G_{\Lambda\Lambda}^t P(\nu)\langle j - 2 \text{def}(\Lambda) \rangle$. Finally by Theorem 4.2, we see that $G_{\Lambda\Lambda}^t P(\nu)\langle j - 2 \text{def}(\Lambda) \rangle$ is a direct sum of some number of copies of a single projective module $P(\gamma)$ (possibly shifted in different degrees) for some $\gamma \in \Lambda^\circ$. Combined with Theorem 6.1(ii) again, this shows that $\text{soc } V(\lambda)$ is also a direct sum of some number of copies of a

single irreducible module $L(\gamma)$ (possibly shifted in different degrees). But $V(\lambda)$ itself has a multiplicity-free composition series according to [BS, Theorem 5.2]. Hence its socle must actually be irreducible. \square

Corollary 6.7. *The radical and socle filtrations of cell modules both coincide with the grading filtration. In particular, cell modules are rigid.*

Proof. This follows from the lemma combined with Lemma 5.10 and [BGS, Proposition 2.4.1]. \square

7. KOSTANT MODULES

In the last section, we construct an analogue of the (generalised) BGG resolution from [BGG, L] in the diagrammatic setting. Throughout the section, we work with a fixed block Λ .

Homomorphisms between neighbouring cell modules. Recall we say two vertices $i < j$ of a weight $\lambda \in \Lambda$ are *neighbours* if they are separated only by \circ 's and \times 's.

Lemma 7.1. *Let $\mu \in \Lambda$ be a weight and $i < j$ be neighbouring vertices of μ labelled \wedge and \vee , respectively. Let λ be the weight obtained from μ by interchanging the labels on these two vertices. Then the linear map*

$$f_{\lambda,\mu} : V(\lambda)\langle 1 \rangle \rightarrow V(\mu),$$

$$(c\lambda) \mapsto \begin{cases} (c\mu) & \text{if } c \text{ has a cup joining the } i\text{th and } j\text{th vertices,} \\ 0 & \text{otherwise,} \end{cases}$$

is a graded K_Λ -module homomorphism of degree zero. Every K_Λ -module homomorphism from $V(\lambda)$ to $V(\mu)$ is a multiple of $f_{\lambda,\mu}$.

Proof. The second statement follows at once from the first, since $f_{\lambda,\mu}$ is clearly a non-zero map and the space $\text{Hom}_{K_\Lambda}(V(\lambda), V(\mu))$ is at most one-dimensional by [BS, (5.12), (5.14)].

For the first statement, recall that the projective indecomposable module $P := P(\lambda) = K_\Lambda e_\lambda$ has a filtration by cell modules constructed explicitly in [BS, Theorem 5.1]. In particular, if we let M (resp. N) be the submodule of P spanned by all basis vectors $(c\nu\bar{\lambda})$ such that $\nu \neq \lambda$ (resp. $\nu \neq \lambda, \mu$), then $P/M \cong V(\lambda)$ and $M/N \cong V(\mu)\langle 1 \rangle$. Right multiplication by $(\underline{\lambda}\mu\bar{\lambda}) \in K_\Lambda$ defines an endomorphism $f : P \rightarrow P$ that is homogeneous of degree two. By [BS, Theorem 4.4(i)], f maps any basis vector $(c\nu\bar{\lambda})$ of P to a linear combination of basis vectors of the form $(c\gamma\bar{\lambda})$ where $\nu < \gamma \geq \mu$. It follows that $f(P) \subseteq M$ and $f(M) \subseteq N$. Hence f induces a degree two homomorphism

$$f_{\lambda,\mu} : V(\lambda) \cong P/M \rightarrow M/N \cong V(\mu)\langle 1 \rangle.$$

To see that this is exactly the map $f_{\lambda,\mu}$ from the statement of the lemma, it remains to observe by [BS, Theorem 4.4(iii)] that

$$f((c\lambda\bar{\lambda})) = (c\lambda\bar{\lambda})(\underline{\lambda}\mu\bar{\lambda}) \equiv \begin{cases} (c\mu\bar{\lambda}) & (\text{mod } N) \text{ if } c\mu \text{ is oriented,} \\ 0 & (\text{mod } N) \text{ otherwise.} \end{cases}$$

Since $c\lambda$ is oriented *a priori* and λ differs from μ only at the vertices i and j , the condition that $c\mu$ is oriented is equivalent to saying that c has a cup joining the i th and j th vertices. \square

Kostant weights. A *Kostant weight* means a weight $\mu \in \Lambda$ such that

$$\sum_{i \geq 0} \dim \text{Ext}_{K_\Lambda}^i(V(\lambda), L(\mu)) \leq 1 \quad (7.1)$$

for every $\lambda \in \Lambda$. The following lemma gives a combinatorial classification of such weights: they are the weights that are “ $\wedge \vee \wedge \vee$ -avoiding.” In view of Remark 5.1, this result can also be deduced from existing literature (at least for bounded weights); see e.g. [BH] and the references therein.

Lemma 7.2. *For $\mu \in \Lambda$, the following are equivalent:*

- (i) $p_{\lambda, \mu}(q) = q^{\ell(\lambda, \mu)}$ for all $\lambda \leq \mu$;
- (ii) μ is a Kostant weight;
- (iii) μ is $\wedge \vee \wedge \vee$ -avoiding, by which we mean it is impossible to find vertices $i < j < k < l$ whose labels in μ are \wedge, \vee, \wedge and \vee , respectively.

Proof. (i) \Rightarrow (ii). This is clear from Corollary 5.5.

(ii) \Rightarrow (iii). Assume that (iii) is false. Choose vertices $i < j < k < l$ labelled \wedge, \vee, \wedge and \vee , respectively, so that $(l-i)$ is minimal and j and k are neighbours. Let λ be the weight obtained from μ by interchanging the labels on the i th and l th vertices. Then $\bar{\mu}$ has a small cap connecting the j th and k th vertices, and $\ell_j(\lambda, \mu) = 1$. We deduce from (5.3) that $p_{\lambda, \mu}(1) \geq 2$, so that μ is not a Kostant weight by Corollary 5.5.

(iii) \Rightarrow (i). Assume that μ is $\wedge \vee \wedge \vee$ -avoiding, and we are given $\lambda \leq \mu$. Let $i < j$ be neighbouring vertices labelled \vee and \wedge in μ , respectively. So there is a small cap in $\bar{\mu}$ joining the i th and j th vertices. By the assumption on μ , it is either the case that no vertex $\leq i$ in μ is labelled \wedge , or that no vertex $> i$ in μ is labelled \vee . In the former case, the fact that $\lambda \leq \mu$ implies that all of the vertices $\leq i$ are labelled in the same way in λ as in μ , hence $\ell_i(\lambda, \mu) = 0$. In the latter case, all the vertices $> i$ are labelled in the same way in λ as in μ , and of course λ and μ are in the same block, so we can again deduce that $\ell_i(\lambda, \mu) = 0$. We deduce from (5.3) that $p_{\lambda, \mu}(q) = q^{\ell(\lambda, \mu)}$, because the label in every small cap of $\bar{\mu}$ is zero. \square

The BGG resolution. Let $\mu \in \Lambda$ be any weight. Following a construction going back to work of Bernstein, Gelfand and Gelfand [BGG] and Lepowsky [L], we are going to define a complex of graded K_Λ -modules

$$\cdots \longrightarrow V_2 \xrightarrow{d_1} V_1 \xrightarrow{d_0} V_0 \xrightarrow{\varepsilon} L(\mu) \longrightarrow 0, \quad (7.2)$$

where

$$V_n := \bigoplus_{\substack{\lambda \leq \mu \\ \ell(\lambda, \mu) = n}} V(\lambda)\langle n \rangle. \quad (7.3)$$

We will refer to this as the *BGG complex*. It will turn out that it is exact if and only if μ is a Kostant weight (as described combinatorially by Lemma 7.2).

To define the maps in the BGG complex, note to start with that $V_0 = V(\mu)$. So we can simply define the map ε to be the canonical surjection $V(\mu) \twoheadrightarrow L(\mu)$. To define the other maps we need a little more preparation. Introduce the notation $\lambda \rightarrow \nu$ to indicate that $\lambda \leq \nu$ and $\ell(\lambda, \nu) = 1$. In that case, there is a canonical homomorphism $f_{\lambda, \nu} : V(\lambda)\langle 1 \rangle \rightarrow V(\nu)$ thanks to Lemma 7.1. Call a quadruple of weights $(\lambda, \nu, \nu', \lambda')$ a *square* if

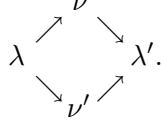

By an easy variation on [BGG, Lemma 10.4], it is possible to pick a sign $\sigma(\lambda, \nu)$ for each arrow $\lambda \rightarrow \nu$ such that for every square the product of the signs associated to its four arrows is equal to -1 . We can now define the differential $d_n : V_{n+1} \rightarrow V_n$ to be the sum of the maps

$$\sigma(\lambda, \nu) f_{\lambda, \nu} : V(\lambda)\langle n+1 \rangle \rightarrow V(\nu)\langle n \rangle$$

for each $\lambda \rightarrow \nu \leq \mu$ with $\ell(\nu, \mu) = n$.

Now we can formulate the main result of the section. It shows that (7.2) is indeed a complex for any $\mu \in \Lambda$, and it is exact if and only if μ is a Kostant weight. Hence, for Kostant weights, the BGG complex is actually a *resolution* of $L(\mu)$ by multiplicity-free direct sums of cell modules. Our proof mimics the general idea of the argument in [L, Lemma 4.4] (see also [HK, Lemma 5] and [HK, Proposition 6]) in the diagrammatic setting.

Theorem 7.3. *The following hold for any $\mu \in \Lambda$:*

- (i) $\text{im } d_{n+1} = \ker d_n$ for each $n \geq 0$;
- (ii) $\text{im } d_0 \subseteq \ker \varepsilon$ with equality if and only if μ is a Kostant weight.

Proof. We proceed in several steps.

Step one: $\text{im } d_0 \subseteq \ker \varepsilon$. This is clear as the image of d_0 is contained in the unique maximal submodule of V_0 , which is $\ker \varepsilon$.

Step two: $\text{im } d_{n+1} \subseteq \ker d_n$ for any $n \geq 0$. Given $\lambda \leq \mu$, it is convenient to let

$$i_\lambda : V(\lambda)\langle m \rangle \hookrightarrow V_m, \quad p_\lambda : V_m \twoheadrightarrow V(\lambda)\langle m \rangle$$

be the natural inclusion and projection maps, where $m := \ell(\lambda, \mu)$. We need to show $d_n \circ d_{n+1} = 0$, which follows if we check that the map

$$r_{\lambda, \lambda'} := p_{\lambda'} \circ d_n \circ d_{n+1} \circ i_\lambda : V(\lambda)\langle n+2 \rangle \rightarrow V(\lambda')\langle n \rangle$$

is zero for every $\lambda, \lambda' \leq \mu$ with $\ell(\lambda, \mu) = n+2$ and $\ell(\lambda', \mu) = n$. The map $r_{\lambda, \lambda'}$ is trivially zero unless there exists a weight ν such that $\lambda \rightarrow \nu \rightarrow \lambda'$. Suppose that ν is such a weight, and let $i < j$ (resp. $k < l$) be the pair of neighbouring vertices that are labelled differently in ν compared to λ (resp. in λ' compared to ν). If $\{i, j\} \cap \{k, l\} \neq \emptyset$, then ν is the unique weight such that $\lambda \rightarrow \nu \rightarrow \lambda'$, and it is clear from the explicit description from Lemma 7.1 that

$$r_{\lambda, \lambda'} = \sigma(\lambda, \nu) \sigma(\nu, \lambda') f_{\nu, \lambda'} \circ f_{\lambda, \nu}$$

is zero. If $\{i, j\} \cap \{k, l\} = \emptyset$, then there is just one more weight $\nu' \neq \nu$ with $\lambda \rightarrow \nu' \rightarrow \lambda'$, namely, the weight obtained from λ by interchanging the labels on the k th and l th vertices. In this case, $(\lambda, \nu, \nu', \lambda')$ is a square, and

$$r_{\lambda, \lambda'} = \sigma(\lambda, \nu)\sigma(\nu, \lambda')f_{\nu, \lambda'} \circ f_{\lambda, \nu} + \sigma(\lambda, \nu')\sigma(\nu', \lambda')f_{\nu', \lambda'} \circ f_{\lambda, \nu'}.$$

This time, Lemma 7.1 gives that $f_{\nu, \lambda'} \circ f_{\lambda, \nu} = f_{\nu', \lambda'} \circ f_{\lambda, \nu'}$. Hence $r_{\lambda, \lambda'} = 0$ as $\sigma(\lambda, \nu)\sigma(\nu, \lambda') = -\sigma(\lambda, \nu')\sigma(\nu', \lambda')$ by the choice of signs.

Step three: $\text{im } d_{n+1} = \ker d_n$ for any $n \geq 0$. It suffices to show that e_γ annihilates $\ker d_n / \text{im } d_{n+1}$ for all $\gamma \in \Lambda$. If $\gamma \not\prec \mu$ then $e_\gamma V(\lambda) = \{0\}$ for all $\lambda < \mu$, and the conclusion is trivial. So we may assume that $\gamma < \mu$. This means that γ is not maximal in the Bruhat order, so we can pick neighbouring vertices $i < j$ of γ that are labelled \vee and \wedge , respectively. For any $m \geq 0$ and symbols $a, b \in \{\vee, \wedge\}$, let

$$\Lambda_m^{ab} := \{\lambda \leq \mu \mid \ell(\lambda, \mu) = m, \text{ vertices } i, j \text{ of } \lambda \text{ are labelled } a, b, \text{ respectively}\}.$$

Note that there is a bijection $\Lambda_{m+1}^{\vee\wedge} \rightarrow \Lambda_m^{\wedge\vee}, \lambda \mapsto \lambda^s$, where λ^s denotes the weight obtained from λ by interchanging the labels on the i th and j th vertices. Also for any $\lambda \leq \mu$ with $\ell(\lambda, \mu) = m$, the space $e_\gamma V(\lambda)\langle m \rangle$ is one-dimensional with basis $(\underline{\gamma}\lambda)$ if $\lambda \in \Lambda_m^{\vee\wedge} \cup \Lambda_m^{\wedge\vee}$, and $e_\gamma V(\lambda)\langle m \rangle = \{0\}$ if $\lambda \in \Lambda_m^{\wedge\wedge} \cup \Lambda_m^{\vee\vee}$. Finally, for $\bar{\lambda} \in \Lambda_{m+1}^{\vee\wedge}$, we have that

$$d_m((\underline{\gamma}\bar{\lambda})) \equiv \sigma(\lambda, \lambda^s)(\underline{\gamma}\lambda^s) \pmod{\bigoplus_{\nu \in \Lambda_m^{\vee\wedge}} V(\nu)\langle m \rangle}. \quad (7.4)$$

Now take $x \in e_\gamma(\ker d_n) \subseteq V_{n+1}$. Using the observations just made, we can write $x = \sum_{\lambda \in \Lambda_{n+2}^{\vee\wedge}} a_\lambda(\underline{\gamma}\lambda^s) + \sum_{\lambda \in \Lambda_{n+1}^{\wedge\vee}} b_\lambda(\underline{\gamma}\lambda)$ for unique $a_\lambda, b_\lambda \in \mathbb{F}$. By (7.4), if we let $y := \sum_{\lambda \in \Lambda_{n+2}^{\vee\wedge}} a_\lambda \sigma(\lambda, \lambda^s)(\underline{\gamma}\lambda)$, then

$$d_{n+1}(y) \equiv x \pmod{\bigoplus_{\nu \in \Lambda_{n+1}^{\vee\wedge}} V(\nu)\langle n+1 \rangle}.$$

Hence $x = d_{n+1}(y) + \sum_{\lambda \in \Lambda_{n+1}^{\wedge\vee}} b'_\lambda(\underline{\gamma}\lambda)$ for some $b'_\lambda \in \mathbb{F}$. Finally we apply the map d_n and use (7.4) again to see that

$$0 = d_n(x) \equiv \sum_{\lambda \in \Lambda_{n+1}^{\wedge\vee}} b'_\lambda \sigma(\lambda, \lambda^s)(\underline{\gamma}\lambda^s) \pmod{\bigoplus_{\nu \in \Lambda_n^{\vee\wedge}} V(\nu)\langle n \rangle}.$$

It follows that $b'_\lambda = 0$ for all $\lambda \in \Lambda_{n+1}^{\wedge\vee}$, hence $x = d_{n+1}(y)$. This shows that $e_\gamma(\ker d_n) \subseteq e_\gamma(\text{im } d_n)$, as required.

Step four: $\text{im } d_0 = \ker \epsilon$ if and only if μ is a Kostant weight. By what we have established so far, $\text{im } d_0 = \ker \epsilon$ if and only if the Euler characteristic of our complex (computed in $[\text{Mod}_f(K_\Lambda)]$) is zero, i.e. $[L(\mu)] = \sum_{\lambda \leq \mu} (-q)^{\ell(\lambda, \mu)} [V(\lambda)]$. By Corollary 5.4 and [BS, (5.14)], we know that $[L(\mu)] = \sum_{\lambda \leq \mu} p_{\lambda, \mu}(-q) [V(\lambda)]$. Hence $\text{im } d_0 = \ker \epsilon$ if and only if $p_{\lambda, \mu}(-q) = (-q)^{\ell(\lambda, \mu)}$ for each $\lambda \leq \mu$. Applying Lemma 7.2 this is if and only if μ is a Kostant weight. \square

REFERENCES

- [ADL] I. Ágoston, V. Dlab and E Lukács, Quasi-hereditary extension algebras, *Algebr. Represent. Theory* **6** (2003), 97–117.
- [Ba] E. Backelin, Koszul duality for parabolic and singular category \mathcal{O} , *Represent. Theory* **3** (1999), 139–152.
- [BB] A. Beilinson and J. Bernstein, Localisation de \mathfrak{g} -modules, *C. R. Acad. Sci. Paris Ser. I Math.* **292** (1981), 15–18.
- [BGS] A. Beilinson, V. Ginzburg and W. Soergel, Koszul duality patterns in representation theory, *J. Amer. Math. Soc.* **9** (1996), 473–527.
- [BGG] J. Bernstein, I. Gelfand and S. Gelfand, “Differential operators on the base affine space and a study of \mathfrak{g} -modules”, in: *Lie Groups and their Representations (Budapest, 1971)*, pp. 21–64, Halsted, New York, 1975.
- [BH] B. Boe and M. Hunziker, Kostant modules in blocks of category \mathcal{O}_S , *Commun. Alg.* **37** (2009), 323–356.
- [Br] T. Braden, Perverse sheaves on Grassmannians, *Canad. J. Math.* **54** (2002), 493–532.
- [B] J. Brundan, Kazhdan-Lusztig polynomials and character formulae for the Lie superalgebra $\mathfrak{gl}(m|n)$, *J. Amer. Math. Soc.* **16** (2003), 185–231.
- [BS] J. Brundan and C. Stroppel, Highest weight categories arising from Khovanov’s diagram algebra I: cellularity; [arXiv:0806.1532v1](https://arxiv.org/abs/0806.1532v1).
- [CKL] S.-J. Cheng, J.-H. Kwon and N. Lam, A BGG-type resolution for tensor modules over general linear superalgebra, *Lett. Math. Phys.* **84** (2008), 75–87.
- [CPS] E. Cline, B. Parshall and L. Scott, The homological dual of a highest weight category, *Proc. London Math. Soc.* **68** (1994), 296–316.
- [HK] I. Heckenberger and S. Kolb, On the Bernstein-Gelfand-Gelfand resolution for Kac-Moody algebras and quantized enveloping algebras, *Transform. Groups* **12** (2007), 647–655.
- [I] R. Irving, Projective modules in the category \mathcal{O}_S : self-duality, *Trans. Amer. Math. Soc.* **291** (1985), 701–732.
- [KL] D. Kazhdan and G. Lusztig, Representations of Coxeter groups and Hecke algebras, *Invent. Math.* **53** (1979), 165–184.
- [K] M. Khovanov, A functor-valued invariant of tangles, *Alg. Geom. Topology* **2** (2002), 665–741.
- [KSX] S. Koenig, H. Slungard and C. Xi, Double centralizer properties, dominant dimension and tilting modules, *J. Algebra* **240** (2001), 393–412.
- [LS] A. Lascoux and M.-P. Schützenberger, Polynômes de Kazhdan et Lusztig pour les Grassmanniennes, *Astérisque* **87–88** (1981), 249–266.
- [L] J. Lepowsky, A generalization of the Bernstein-Gelfand-Gelfand resolution, *J. Algebra* **49** (1977), 496–511.
- [MOS] V. Mazorchuk, S. Ovsienko and C. Stroppel, Quadratic duals, Koszul dual functors, and applications, *Trans. Amer. Math. Soc.* **361** (2009), 1129–1172.
- [MVS] R. Martínez Villa and M. Saorín, Koszul equivalences and dualities, *Pacific J. Math.* **214** (2004), 359–378.
- [R] R. Rouquier, q -Schur algebras and complex reflection groups, *Mosc. Math. J.* **8** (2008), 119–158.
- [S] W. Soergel, Kategorie \mathcal{O} , perverse Garben und Moduln über den Koinvarianten zur Weylgruppe, *J. Amer. Math. Soc.* **3** (1990), 421–445.
- [S1] C. Stroppel, Category \mathcal{O} : quivers and endomorphism rings of projectives, *Represent. Theory* **7** (2003), 322–345.
- [S2] C. Stroppel, Categorification of the Temperley-Lieb category, tangles, and cobordisms via projective functors, *Duke Math. J.* **126** (2005), 547–596.
- [S3] C. Stroppel, TQFT with corners and tilting functors in the Kac-Moody case; [arXiv:math/0605103](https://arxiv.org/abs/math/0605103).
- [S4] C. Stroppel, Perverse sheaves on Grassmannians, Springer fibres and Khovanov homology, to appear in *Compositio Math.*; [arXiv:math/0608234v2](https://arxiv.org/abs/math/0608234v2).

- [V] D. Vogan, Irreducible representations of semisimple Lie groups II: the Kazhdan-Lusztig conjectures, *Duke Math. J.* **46** (1979), 805–859.
- [W] C. Weibel, *An Introduction to Homological Algebra*, CUP, 1994.
- [Z] A. Zelevinsky, Small resolutions of singularities of Schubert varieties, *Funct. Anal. Appl.* **17** (1983), 142–144.

DEPARTMENT OF MATHEMATICS, UNIVERSITY OF OREGON, EUGENE, OR 97403, USA
E-mail address: `brundan@uoregon.edu`

DEPARTMENT OF MATHEMATICS, UNIVERSITY OF BONN, 53115 BONN, GERMANY
E-mail address: `stroppel@math.uni-bonn.de`